

PART 1 - GENERAL

1.1 PROJECT – H17-0111-WW

A. COASTAL CAROLINA UNIVERSITY

ATHENEUM HALL UNDERGROUND HW REPLACEMENT

1.2 ENGINEER

- A. DWG Consulting Engineers, Inc.  
1009 Anna Knapp Blvd Suite 200, Mt. Pleasant, SC 29464  
(843) 849-1141

1.3 RELATED DOCUMENTS

- A. This Addendum consists of 27 page(s) including attachments.
- B. To Prime Bidders of Record:
1. This addendum forms a part of the Contract Documents and modifies the original Project Manual and Drawings. Acknowledge receipt of this addendum on the Bid Form. Failure to do so may cause a bid to be rejected as unresponsive as outlined in the Instructions to Bidders.

PART 2 - ADDENDUM ITEMS

2.1 GENERAL

- A. The following changes/clarifications shall be made to the drawings. Revised drawings are attached.
1. E001
    - a. Boiler disconnect clarified to be lockable.
  2. E101
    - a. Location of disconnects clarified to be mounted on exterior wall of building.
  3. M002
    - a. Chemical Shot Feeder Detail added.
    - b. On slab pipe support detail added.
    - c. Boiler piping detail clarified.
    - d. Drain pit detail removed.
  4. M003
    - a. Drain method clarified to splashblock.
  5. M101
    - a. Hot Box Information clarified.
    - b. Emergency Boiler shutdown switch location clarified.
    - c. Demolition scope in existing plant clarified.

- d. Shot feeder location clarified.
- e. Air separator and expansion tank model number information clarified.
- f. Some pipe tags added/clarified.

B. The following changes/clarifications shall be made to the Project Manual. Revised sheets are attached.

- 1. Specification section 230719 'HVAC Piping Insulation' has been modified.
- 2. Specification Section 232113.13 'Underground Direct Buried Hydronic Piping' added to project manual.

Questions:

- 1. Q: The drawings show drain pit detail (M002) but the boiler is not a condensing boiler. Can this be ignored as it is not needed for condensate from the boiler?

A: Drain pit detail has been removed in this Addendum.

- 2. Q: Are we to supply a new hot water pump(s) in the mechanical room? Or is this owner supplied? It is listed on page M001 of plans but does not indicate that we will be reusing what is already in place.

A: As a general statement, all components that are shown but aren't indicated as owner provided shall be contractor provided. The boiler itself is the only item that is indicated as owner provided. The new pumps are shown to be installed in the hot box outside adjacent to the boiler, not in the mechanical room.

- 3. Q: Are we to supply a new boiler pump for the boiler? Or is this owner supplied? It is listed on page M001 of plans but does not indicate that we will be reusing what is already in place.

A: See response to Question 2.

- 4. Q: Are we to supply a hot water shot feeder? or is there already one in the loop?

A: See response to Question 2. The shot feeder shall be provided as new. There is not one currently in the loop.

- 5. Q: There was no expansion tank in the mechanical room? It shows one on the plans. Is this to be supplied by the contractor? If so do you have specs on it?

A: See response to Question 2. Size and Model number information has been included in this Addendum.

END OF ADDENDUM NO. 1

## ELECTRICAL SYSTEMS SEISMIC REQUIREMENTS PER IBC-2018/ASCE 7-16

- A. PER THE 2018 INTERNATIONAL BUILDING CODE, MECHANICAL, PLUMBING AND ELECTRICAL EQUIPMENT AND COMPONENTS, INCLUDING THEIR SUPPORTS AND ATTACHMENTS, SHALL BE DESIGNED FOR SEISMIC FORCES IN ACCORDANCE WITH CHAPTER 13 OF ASCE 7-16.
- B. EXTERIOR EQUIPMENT (INCLUDING ROOF CURBS, RAILS, SUPPORTS) EXPOSED TO WIND SHALL BE DESIGNED AND INSTALLED TO RESIST THE WIND PRESSURES DETERMINED IN ACCORDANCE WITH CHAPTER 26 TO 29 OF ASCE 7-16.
- C. WHERE DESIGN FOR SEISMIC AND WIND LOADS IS REQUIRED, THE MORE DEMANDING FORCE MUST BE USED.
- D. REFERENCE THE STRUCTURAL DRAWINGS FOR SITE SPECIFIC INFORMATION ON SEISMIC DESIGN CATEGORY, WIND SPEEDS, ETC.
- E. USE THE TABLE BELOW TO DETERMINE SEISMIC RESTRAINT REQUIREMENTS FOR EACH COMPONENT.
- F. FOR ALL COMPONENTS REQUIRING SEISMIC RESTRAINT, THE COMPONENT SUPPORTS AND ATTACHMENTS SHALL BE DESIGNED BY A REGISTERED DESIGN PROFESSIONAL REGISTERED IN THE STATE THE JOB IS LOCATED. SUBMITTALS MUST INCLUDE STAMPED AND SIGNED DRAWINGS AND CALCULATIONS.
- G. WHERE SEISMIC RESTRAINT IS REQUIRED, HOUSEKEEPING PADS NEEDED FOR THE INSTALLATION OF EQUIPMENT UNDER THIS CONTRACT MUST BE DESIGNED BY THE SEISMIC ENGINEER. DO NOT POUR ANY HOUSEKEEPING PADS PRIOR TO THE RECEIPT OF THE APPROVED SEISMIC SUBMITTAL.
- H. SEISMIC RESTRAINTS FOR DUCTWORK, PIPING, CONDUIT, CABLE TRAYS AND BUS DUCT MUST BE SHOWN ON LAYOUT DRAWINGS SHOWING SPECIFIC RESTRAINT LOCATIONS ALONG WITH ACCOMPANYING DETAILS AND CALCULATIONS.

### ELECTRICAL COMPONENT IMPORTANCE FACTOR (Ip) DESIGNATION

Ip = 1.0

- ALL ASSOCIATED ELECTRICAL WORK UNLESS NOTED OTHERWISE

### SEISMIC DESIGN CATEGORIES D,E,F

#### COMPONENT IMPORTANCE FACTOR (Ip)

1.0

COMPONENT IDENTIFICATION	SEISMIC RESTRAINT REQUIREMENT	NOTES
FLOOR MOUNTED	RESTRAIN ALL	1,2
WALL MOUNTED	RESTRAIN ALL	1,2
COMPONENT SUPPORTS	RESTRAIN ALL	1
SUSPENDED EQUIPMENT	RESTRAIN ALL	1
SINGLE CONDUIT	RESTRAIN IF ≥ 2.5"	3
CABLE TRAY/BUS DUCT TRAPEZED CONDUIT	DO NOT DELETE ON TRAPEZE > 2.5". RESTRAIN IF TOTAL WEIGHT OF SUSPENDED COMPONENT > 10 LBS/FT	3
COMPONENT CERTIFICATION	NOT REQUIRED	-

#### NOTES:

1. EQUIPMENT 20 LBS. OR LESS IS EXEMPT IF THE COMPONENT IS POSITIVELY ATTACHED TO THE STRUCTURE AND FLEXIBLE CONNECTIONS ARE PROVIDED BETWEEN THE COMPONENT AND ASSOCIATED DUCTWORK, PIPING AND CONDUIT.
2. RESTRAINTS ARE NOT REQUIRED IF THE COMPONENT WEIGHS 400 LBS. OR LESS, IS MOUNTED WITH THE CENTER MASS AT 4' OR LESS ABOVE A FLOOR, IS POSITIVELY ATTACHED TO THE STRUCTURE, AND HAS FLEXIBLE CONNECTIONS BETWEEN THE COMPONENT AND ASSOCIATED DUCTWORK, PIPING AND CONDUIT.
3. RESTRAINT IS NOT REQUIRED IF THE CONDUIT IS SUPPORTED BY HANGERS AND EACH HANGER IN THE RUN IS 12" IN. OR LESS IN LENGTH FROM THE TOP OF THE PIPE TO THE SUPPORTING STRUCTURE, WHERE PIPES ARE SUPPORTED ON A TRAPEZE, THE TRAPEZE SHALL BE SUPPORTED BY HANGERS HAVING A LENGTH OF 12" IN. OR LESS, WHERE ROD HANGERS ARE USED, THEY SHALL BE EQUIPPED WITH SWIVELS, EYE NUTS OR OTHER DEVICES TO PREVENT BENDING IN THE ROD.
4. THE RESTRAINT OF PENDANT, LAY-IN AND CAN LIGHTS IS ADDRESSED IN ASTM C636 AND E580.
5. COMPONENT CERTIFICATION MUST BE SUPPLIED BY THE EQUIPMENT MANUFACTURER AT TIME OF SUBMITTAL FOR REVIEW BY ENGINEER OF RECORD.

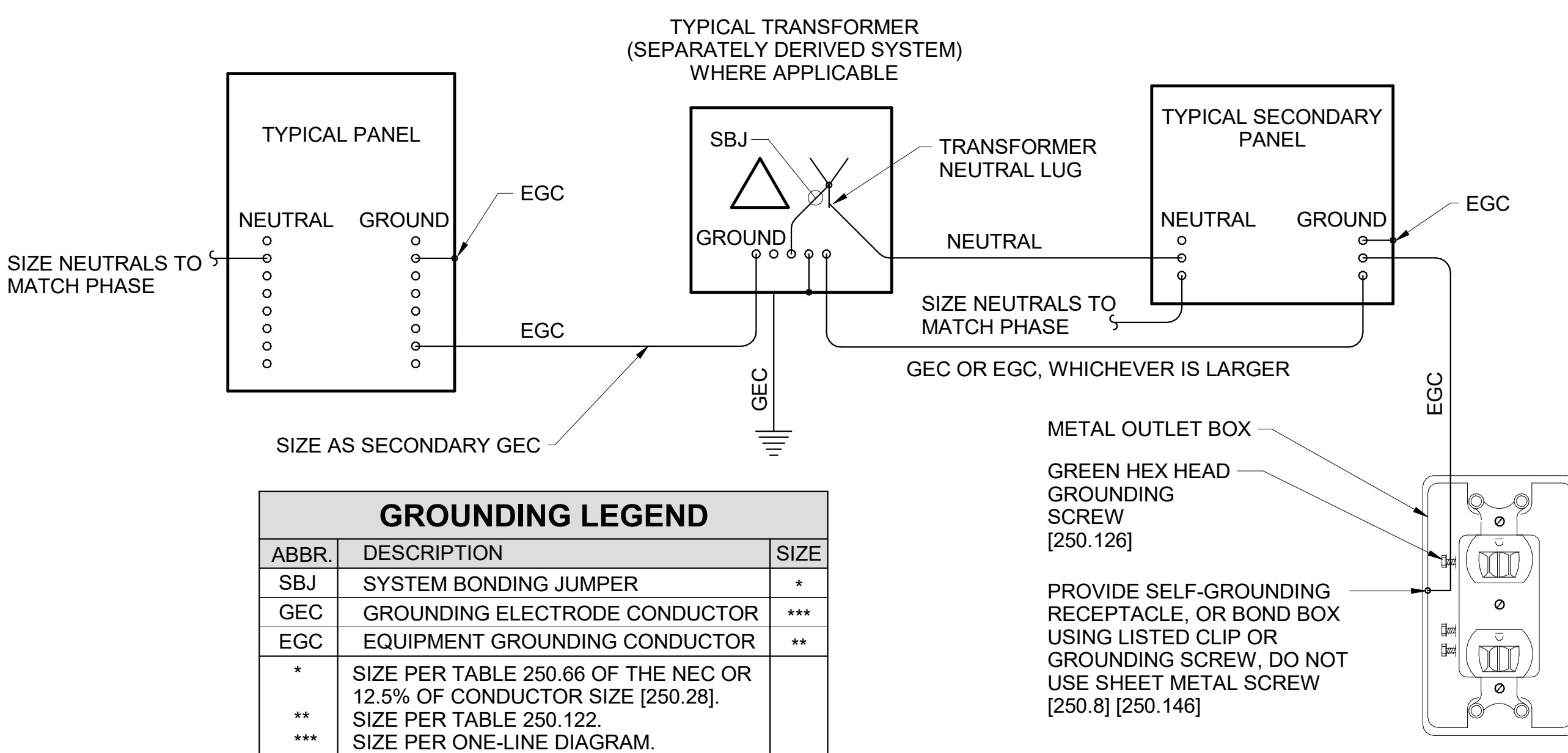

### GROUNDING LEGEND

ABBR.	DESCRIPTION	SIZE
SBJ	SYSTEM BONDING JUMPER	*
GEC	GROUNDING ELECTRODE CONDUCTOR	***
EGC	EQUIPMENT GROUNDING CONDUCTOR	**
*	SIZE PER TABLE 250.66 OF THE NEC OR 12.5% OF CONDUCTOR SIZE [250.28].	
**	SIZE PER TABLE 250.122.	
***	SIZE PER ONE-LINE DIAGRAM.	

#### GROUNDING NOTES:

1. NUMBERS IN BRACKETS REFER TO SPECIFIC SECTIONS OF THE NATIONAL ELECTRICAL CODE.
2. ALL UNDERGROUND OR OTHERWISE INACCESSIBLE GROUND CONNECTIONS AND SPLICES SHALL BE EXOTHERMICALLY WELDED [250.68].
3. GROUND ELECTRODE FOR SEPARATELY DERIVED SYSTEMS SHALL BE THE NEAREST METAL WATER PIPE OR STRUCTURAL METAL. IF EITHER IS NOT AVAILABLE, PROVIDE GROUNDING CONDUCTOR BACK TO MAIN GROUND BUS AT SERVICE ENTRANCE. PROVIDE A GROUND WIRE IN ALL CONDUITS.
4. EARTH SHALL NOT BE USED AS THE SOLE GROUND RETURN PATH FOR ANY EQUIPMENT POWERED UNDER THIS PROJECT. OTHERWISE OVERCURRENT PROTECTION MIGHT NOT WORK, OR IT MIGHT CAUSE POWER QUALITY PROBLEMS.
5. NO ALUMINUM SHALL BE USED FOR GROUNDING WORK WITHOUT THE SPECIFIC WRITTEN PERMISSION OF THE ENGINEER. EXCEPTION: ALUMINUM BUILDING STRUCTURAL MATERIALS SHALL BE BONDED WITH LISTED ALUMINUM EQUIPMENT WITH ALUMINUM TO COPPER CONNECTORS FOR ROUTING COPPER EGCS.
6. ALL METAL ENCLOSURES AND RACEWAYS SHALL BE BONDED TO GROUND [250.86]. FOR CIRCUITS OVER 250V PROVIDE BOND PER [250.97]. STANDARD LOCKNUTS ARE NOT ACCEPTABLE.
7. PROVIDE EGC CONNECTED TO ANY JUNCTION BOX WHERE SPLICE IS MADE [250.148].
8. PROVIDE BOND TO EXPOSED METAL ON ALL MOTORS, PUMPS, AND LIGHTING FIXTURES PER [250.112].

## GENERAL ELECTRICAL NOTES

1. BRANCH CIRCUIT WIRING FOR 20A CIRCUITS SHALL BE SIZED PER WIRE SIZING CHART, WHERE CONDUCTOR AND RACEWAY SIZE ARE SHOWN AT HOMERUN, SUCH SIZE SHALL BE USED FOR THE ENTIRE CIRCUIT. EXCEPTION: FINAL CONNECTION TO DEVICES IN OUTLET BOXES IS NOT REQUIRED TO BE LARGER THAN #12.
2. PRIOR TO ROUGH-IN, IN THE EVENT OF A CONFLICT, NOTIFY THE ENGINEER. MINOR ADJUSTMENTS IN DEVICE LOCATION, SUCH AS 5'-0" IN ANY DIRECTION, SHALL BE DONE AT NO ADDITIONAL COST TO THE OWNER.
3. RACEWAYS SHALL BE INSTALLED CONCEALED IN NEW WALL CONSTRUCTION, ABOVE CEILINGS, BELOW FLOOR AND IN OTHER CAVITIES TO THE GREATEST EXTENT POSSIBLE. EXPOSED RACEWAYS MAY BE USED IN UNFINISHED SPACES, WHERE EXPLICITLY NOTED ON PLANS AND WHERE APPROVED BY THE ENGINEER. LAY OUT EXPOSED RACEWAYS TO MINIMIZE THE NUMBER OF VERTICAL RUNS.
4. BRANCH CIRCUITS ROUTING SHALL COMPLY WITH DETAILS ON DRAWINGS AND SHALL BE COORDINATED WITH THE WORK OF OTHER TRADES BEFORE AND DURING CONSTRUCTION. COORDINATE THE ROUTING OF UNDERGROUND CONDUCTORS/CONDUITS WITH STRUCTURAL FOOTINGS OF BUILDING. BRANCH CIRCUITS SHALL BE ROUTED OVERHEAD UNLESS PRIOR APPROVAL HAS BEEN GRANTED BY THE ENGINEER.
5. A FIRESTOP SYSTEM SHALL BE USED TO SEAL ALL PENETRATIONS OF ELECTRICAL CONDUITS AND CABLES THROUGH FIRE-RATED PARTITIONS. THE FIRESTOP SYSTEM SHALL CONSIST OF A FIRE-RATED CAULK TYPE SUBSTANCE AND HIGH TEMPERATURE FIBER INSULATION BY STI OR APPROVED EQUAL. ONLY METAL CONDUIT SHALL BE USED TO PENETRATE FIRE-RATED PARTITIONS. SEE ARCHITECTURAL DRAWINGS FOR ALL LOCATIONS OF FIRE-RATED WALLS.
6. THE USE OF MC CABLE IS ALLOWED ABOVE ACCESSIBLE CEILINGS AND IN STUD CONSTRUCTION ONLY. HOMERUNS TO PANEL SHALL BE WIRE IN RACEWAY ONLY, MC CABLE IS NOT ACCEPTABLE FOR HOMERUNS. MC CABLE IS ONLY ACCEPTABLE FOR 20A BRANCH CIRCUITS.
7. PROVIDE A LISTED EXPANSION/DEFLECTION FITTING FOR ALL CONDUIT CROSSING EXPANSION JOINTS PER NEC 300.4.H. SEE ARCHITECTURAL DRAWINGS FOR LOCATIONS OF EXPANSION JOINTS.
8. WHEREVER THE WORD "PROVIDE" IS USED ON THE ELECTRICAL DRAWINGS, IT SHALL BE INFERRED TO MEAN "FURNISH AND INSTALL", UNLESS NOTED OTHERWISE.
9. THE ARRANGEMENT, GROUPING, AND ROUTING OF BRANCH CIRCUITS SHALL BE PROVIDED AT THE CONTRACTOR'S DISCRETION IN ACCORDANCE WITH GENERALLY ACCEPTED PRACTICE FOR ELECTRICAL WORK, THE NATIONAL ELECTRICAL CODE REQUIREMENTS, LOCAL ORDINANCES, AND THE FOLLOWING: 1 - A COMMON NEUTRAL MAY BE INSTALLED IN A HOMERUN FOR 2 OR 3 BRANCH CIRCUITS ONLY IF A MEANS TO SIMULTANEOUSLY DISCONNECT ALL UNGROUNDED CONDUCTORS AT THE POINT OF ORIGIN IS PROVIDED PER NEC 210.4.B. 2 - MULTIPLE SINGLE-POLE BRANCH CIRCUITS (UP TO 3 HOTS, 3 NEUTRALS AND 1 GROUND) RATED FOR 30A OR LESS MAY BE PULLED INTO A SINGLE RACEWAY. THE CONTRACTOR SHALL BE RESPONSIBLE FOR SIZING THE RACEWAYS AND DE-RATING CONDUCTORS PER NEC §10.15. 3 - A GROUND CONDUCTOR SHALL BE PROVIDED IN ALL RACEWAYS UNLESS NOTED OTHERWISE.

## GENERAL POWER NOTES

1. PROVIDE NEMA CONFIGURATION RECEPTACLES TO MATCH PLUGS ON EQUIPMENT FURNISHED.

## GENERAL DEMOLITION NOTES

1. ALL ELECTRICAL EQUIPMENT TO BE REMOVED SHALL REMAIN THE PROPERTY OF THE OWNER. THE CONTRACTOR SHALL NOT DISPOSE OF ANY MATERIALS UNTIL RELEASED BY THE OWNER'S PROJECT MANAGER. MATERIALS THAT THE OWNER'S PROJECT MANAGER CHOOSES TO RETAIN SHALL BE DELIVERED BY THE CONTRACTOR TO A LOCATION DESIGNATED BY THE PROJECT MANAGER. ALL OTHER MATERIALS SHALL BE PROPERLY DISPOSED OF BY THE CONTRACTOR.

## GENERAL EXISTING CONDITION NOTES

1. AREAS OF WORK EXIST FOR THIS PROJECT WHICH WERE NOT ACCESSIBLE OR HAD LIMITED ACCESS DURING DESIGN. AS SUCH, CONTRACTOR SHALL VERIFY ALL UTILITIES IN AREA OF WORK BEFORE DEMOLITION OF ANY SERVICE. ANY ELECTRICAL COMPONENTS NOT SHOWN SHALL BE IDENTIFIED AND THE ARCHITECT AND ENGINEER SHALL BE NOTIFIED AS SOON AS POSSIBLE. NO ELECTRICAL REWORK SHALL BE COMMENCED WITHOUT COORDINATION OF BOTH ARCHITECT AND ENGINEER. WHERE INFORMATION SHOWN ON THESE DRAWINGS CONFLICTS WITH VERIFIED FIELD CONDITIONS, IT SHALL BE BROUGHT TO THE ATTENTION OF THE ARCHITECT AND ENGINEER.
2. IN AREAS WHERE THE EXISTING CEILINGS ARE NOT SLATED TO BE REPLACED, THE CONTRACTOR SHALL WORK THROUGH THE EXISTING CEILINGS (SEE ARCHITECTURAL REFLECTED CEILING PLAN FOR AREA OF WORK). THE CONTRACTOR SHALL BE RESPONSIBLE FOR REPLACING ANY DAMAGED TILE OR GRID THAT IS A RESULT OF THEIR WORK. ALL WORK PERFORMED ABOVE EXISTING CEILINGS SHALL BE PERFORMED AFTER HOURS AND SCHEDULED WITH THE OWNER IN ADVANCE.
3. THE CONTRACTOR SHALL BE RESPONSIBLE FOR INSTALLING A FIRESTOP SYSTEM IN ALL PENETRATIONS OF FIRE-RATED FLOORS AND WALLS CREATED BY THE REMOVAL OF EXISTING ELECTRICAL CONDUIT OR CABLES, AS WELL AS THOSE CREATED BY NEWLY INSTALLED CONDUITS AND SLEEVES.
4. WHERE INSTALLATION REQUIRES CUTTING OR DRILLING OF THE EXISTING FLOOR SLAB, THE CONTRACTOR SHALL X-RAY THE EXISTING SLAB PRIOR TO WORK TO ENSURE THAT NO EXISTING UTILITIES OR STRUCTURAL ELEMENTS IN THE SLAB WILL BE COMPROMISED BY THE WORK. NOTIFY THE A/E OF ANY CONFLICTS THAT WILL REQUIRE RELOCATING THE PROPOSED SLAB WORK. THE CONTRACTOR SHALL BE RESPONSIBLE FOR THE REPAIR OF ANY DAMAGED UTILITIES OR STRUCTURAL ELEMENTS CAUSED BY THE SLAB DEMOLITION.

## GENERAL HVAC CONTROLS CONDUIT NOTES

1. PROVIDE CONDUIT FOR HVAC CONTROL CIRCUITS AS REQUIRED TO INTERCONNECT PUMPS/BOILERS TO CONTROL CIRCUITS. ELECTRICAL CONTRACTOR SHALL COORDINATE WITH MECHANICAL CONTRACTOR AND CONTROLS PROVIDER TO DETERMINE SCOPE OF CONDUITS REQUIRED FOR PLUMBING/PUMP CONTROLS. ELECTRICAL CONTRACTOR SHALL PROVIDE ALL REQUIRED CONDUIT, COORDINATE POINTS OF CONNECTION WITH DIVISION 23. PROVIDE PULL CORD IN ALL EMPTY CONDUITS. SEE MECHANICAL PLANS FOR EXACT LOCATIONS OF ALL PLUMBING EQUIPMENT (PUMPS, CONTROLLERS, BOILERS, ETC).

POWER AND TELECOMMUNICATIONS SYMBOL LEGEND			
SYMBOL	DESCRIPTION	SYMBOL	DESCRIPTION
⊕ x	DUPLEX RECEPTACLE	⊕ x	CONTROL SWITCH, "X" INDICATES SWITCH TYPE
⊕ x	GFCI DUPLEX RECEPTACLE	■	PANELBOARD - BRANCH, SURFACE MOUNTED
■	PANELBOARD - DISTRIBUTION, SURFACE MOUNTED		

## ELECTRICAL ABBREVIATIONS

ABBR	DESCRIPTION
(E)	EXISTING
AFC	ABOVE FINISHED CEILING
AFF	ABOVE FINISHED FLOOR
AFG	ABOVE FINISHED GRADE
BFC	BELOW FINISHED CEILING
BFG	BELOW FINISHED GRADE
BOD	BOTTOM OF DEVICE
ECB	ENCLOSED CIRCUIT BREAKER
FACP	FIRE ALARM CONTROL PANEL
FDS	FUSED DISCONNECT SWITCH
GFCI	GROUND-FAULT CIRCUIT-INTERRUPTING
GFI	GROUND-FAULT INTERRUPTING
GP	GENERAL PURPOSE
J-BOX	JUNCTION BOX
KW	KILOWATTS
NEC	NATIONAL ELECTRICAL CODE
NFDS	NON-FUSED DISCONNECT SWITCH
UNO	UNLESS NOTED OTHERWISE
W/	WITH
WP	WEATHERPROOF
RECEPTACLE	DESCRIPTION
WP	WEATHERPROOF

## WIRE SIZING CHART 20 AMP BRANCH CIRCUITS

DISTANCE, 120V	MINIMUM WIRE SIZE
0 - 90 FEET	#12 AWG
90 - 230 FEET	#10 AWG
230 - 446 FEET	#8 AWG

## LINE LEGEND

SYMBOL	DESCRIPTION
—	EXISTING TO REMAIN
—	NEW CONSTRUCTION
- - - -	DEMOLISH

## ELECTRICAL CODES AND STANDARDS (WITH ALL SOUTH CAROLINA MODIFICATIONS)

CODE	DESCRIPTION
IBC (2018)	INTERNATIONAL BUILDING CODE
NFPA 70 (2017)	NATIONAL ELECTRICAL CODE

## EQUIPMENT CONNECTION SCHEDULE

UNIT I.D.	VOLTS	# OF POLES	LOAD (VA)	BRANCH CIRCUIT WIRING	DISCONNECT / STARTER	NOTES
<b>BOILERS</b>						
B-1	120 V	1	876	2#12 & 1#12G IN 3/4" CONDUIT	LOCKABLE 15A FUSED / 30A FDS/ NEMA 4X	1, 2
<b>PUMPS</b>						
BP-1	120 V	1	888	2#12 & 1#12G IN 3/4" CONDUIT	MOTOR RATED SWITCH W/ WP COVER	1
HWP-1	208 V	3	1729	3#12 & 1#12G IN 3/4" CONDUIT	15A FUSED / 30A FDS/ NEMA 4X	1

#### EQUIPMENT NOTES:

1. LOCATE DISCONNECTS AGAINST NEAREST EXTERIOR WALL.
2. BOILER DISCONNECT SHALL BE LOCKABLE TO MEET SC BOILER CODE.

## EXISTING PANELBOARD SCHEDULE

PANEL NAME: PC		VOLTS: 120/208 Wye		A.I.C. RATING: EXISTING							
LOCATION: ELE. CL. 104A		PHASES: 3		MAINS RATING: 225 A							
SOURCE:		WIRES: 4		MAINS TYPE: MAIN LUGS ONLY							
MOUNTING: SURFACE		ENCLOSURE: TYPE 1									
CKT NO.	CIRCUIT DESIGNATION	TRIP	POLES	A	B	C	POLES	TRIP	CIRCUIT DESIGNATION	CKT NO.	
1	(E) WIREMOLD 101A	20 A	1	0 VA / 0 VA			1	20 A	(E) REC 112F	2	
3	(E) SPARE 101A	20 A	1		0 VA / 0 VA		1	20 A	(3) REC 112F	4	
5	EXTERIOR CIRCULATION PUMP BP-1	20 A	1			890 VA / 580 VA				6	
7	EXTERIOR BOILER B-1	20 A	1	880 VA / 580 VA			3	20 A	EXTERIOR SYSTEM PUMP	8	
9	EXTERIOR PUMP ENCLOSURE HEAT	20 A	1		100 VA / 580 VA					10	
11	(E) SPARE	20 A	1			0 VA / 0 VA	1	20 A	(E) SPARE	12	
13	(E) SPARE	20 A	1	0 VA / 0 VA			1	20 A	(E) SPARE	14	
15	(E) SPARE	20 A	1		0 VA / 0 VA		1	20 A	(E) SPARE	16	
17	(E) SPARE	20 A	1			0 VA / 0 VA	1	20 A	(E) SPARE	18	
<b>TOTAL PHASE LOAD:</b>				1450 VA	676	1464					
<b>TOTAL PHASE CURRENT:</b>				13 A	6 A	13 A					
				<b>PANEL TOTALS</b>							
				<b>TOTAL ADDITIONAL LOAD:</b> 3590 VA							
				<b>TOTAL ADDITIONAL CURRENT:</b> 10 A							

#### PANEL SCHEDULE NOTES:

1. UTILIZE EXISTING SPARE BREAKER IN PANEL
2. PROVIDE HANDLE TIE FOR (3) EXISTING 20A-1P SQUARE D QO BREAKERS.

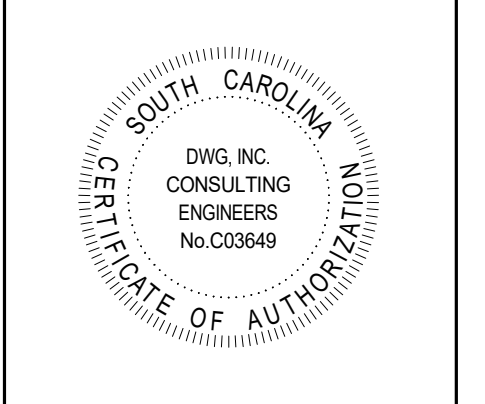

**COASTAL CAROLINA UNIVERSITY**  
 ATHENEUM HALL UNDERGROUND HW REPLACEMENT  
 104 INDEPENDENCE DRIVE  
 CONWAY, SOUTH CAROLINA 29528  
**ELECTRICAL NOTES**

STATE PROJECT NO.:

H17-0111-WW

REV:

1 Addendum 1 03/28/24

DWG JOB NO.:

19162-05

DATE:

01/27/23

DRAWN BY:

MHS

CHECK BY:

MHS/BJJ

SHEET

E001

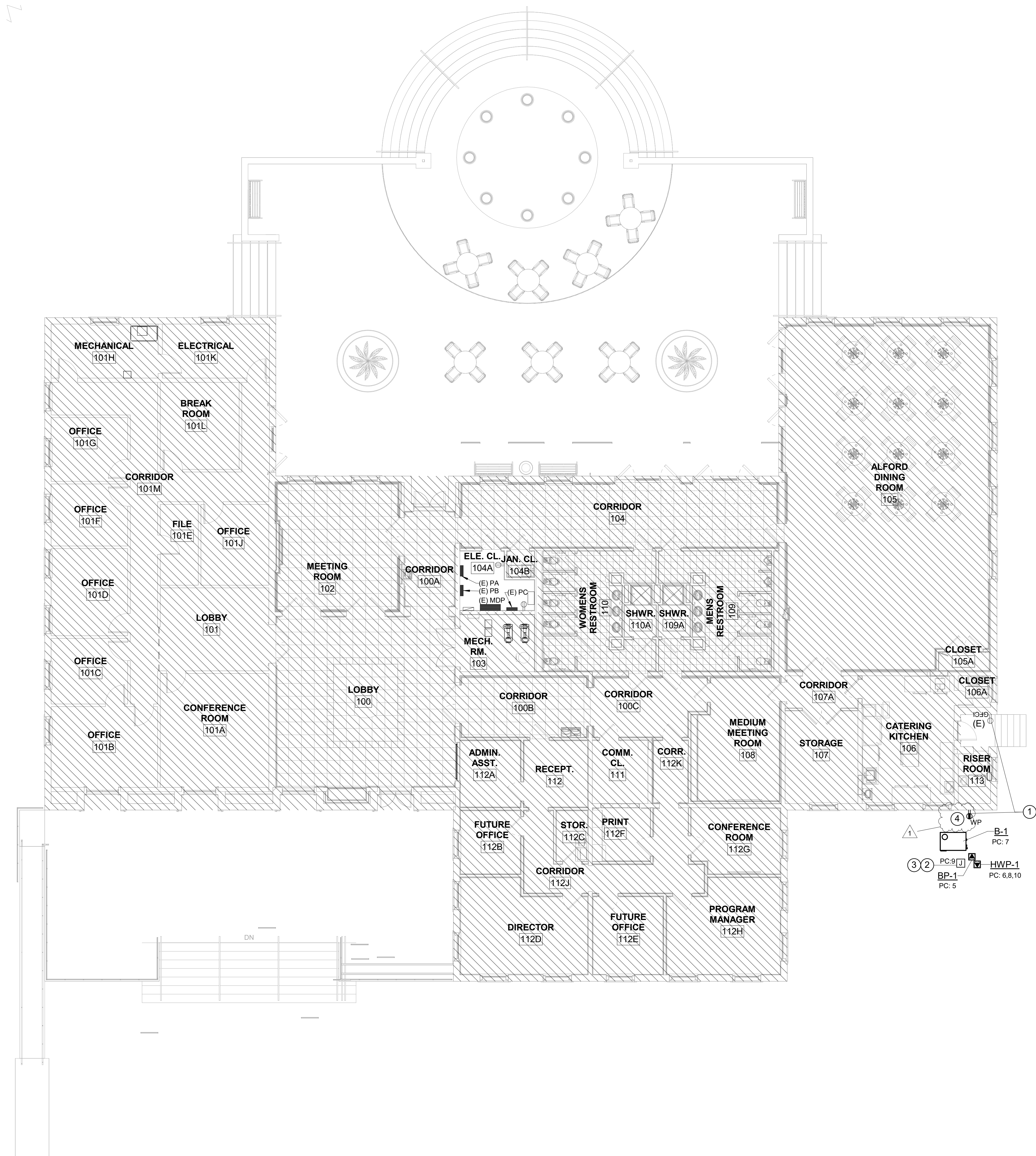
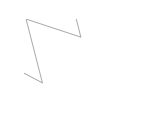

1 POWER PLAN  
E101 SCALE: 1/8" = 1'-0"

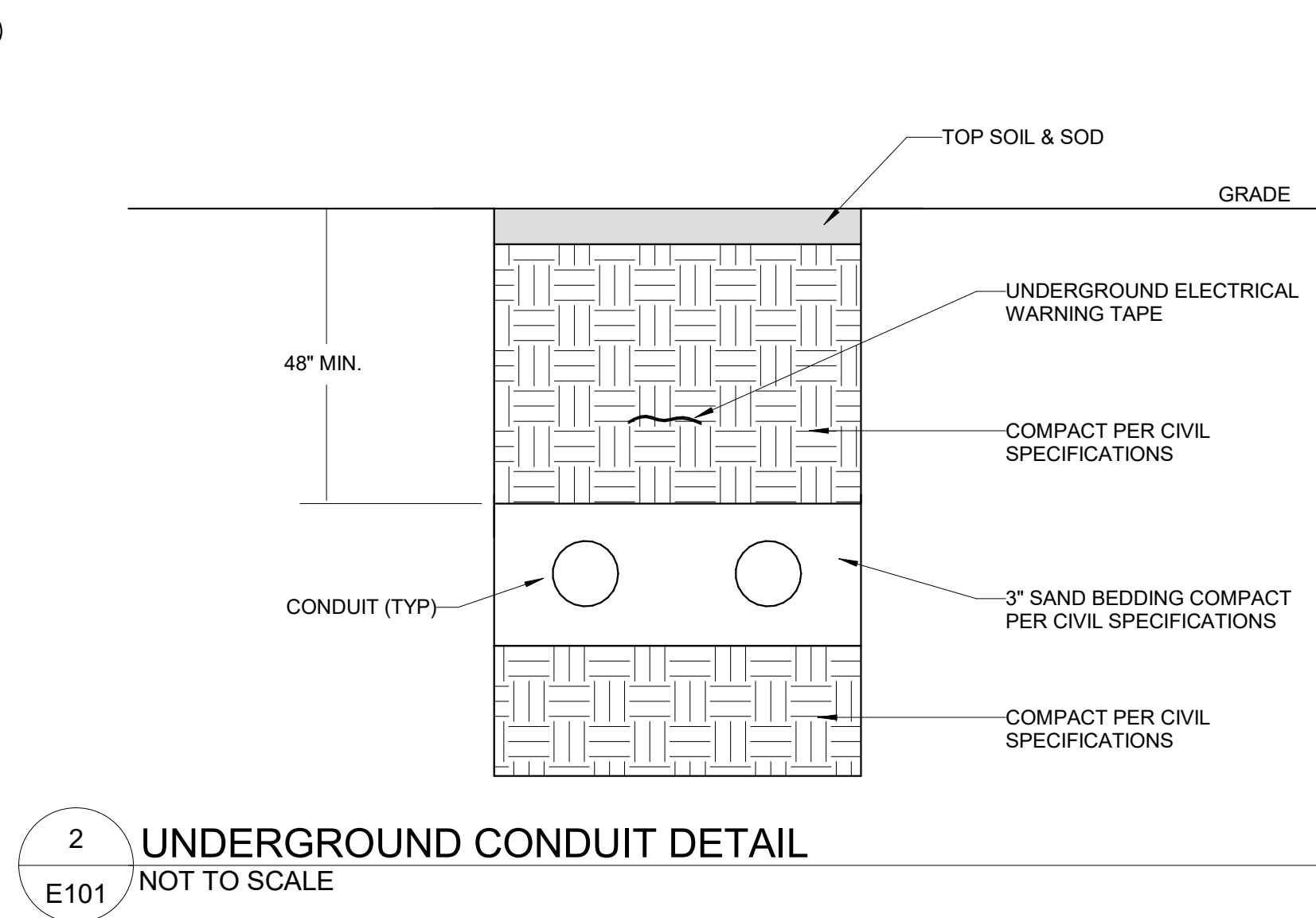

2 UNDERGROUND CONDUIT DETAIL  
E101 NOT TO SCALE



CONSIDERABLE EFFORT HAS BEEN MADE TO DETERMINE THE EXTENT OF UNDERGROUND UTILITIES. SOME LOCATIONS ARE ACTUAL FIELD MEASUREMENTS AND SOME ARE TAKEN FROM UTILITY RECORDS. THIS PLAN DOES NOT WARRANT THAT UTILITIES ARE SHOWN ACCURATELY NOR THAT ALL UTILITIES ARE SHOWN. THE CONTRACTOR SHALL BE RESPONSIBLE FOR DETERMINING THE EXACT LOCATION OF ALL UTILITIES PRIOR TO BEGINNING DIGGING OPERATIONS. CALL PALMETTO UTILITIES LOCATION SERVICE AT 811 A MINIMUM OF 3 WORKING DAYS BEFORE DIGGING. ANY UTILITIES DAMAGED OR DISTURBED DURING CONSTRUCTION SHALL BE RESTORED TO THEIR ORIGINAL CONDITION AT THE CONTRACTOR'S EXPENSE. ADDITIONALLY, THE CONTRACTOR SHALL CONFIRM THE CONNECTION POINTS OF NEW UTILITIES TO EXISTING UTILITIES PRIOR TO BEGINNING NEW CONSTRUCTION.

### GENERAL NOTES

- 1. DIAGONAL HATCHED AREA IS NOT IN ELECTRICAL SCOPE OF WORK.

### RENOVATION KEYNOTES

- 1. TIE NEW RECEPTACLE TO EXISTING EXTERIOR RECEPTACLE CIRCUIT.
- 2. PROVIDE FINAL CONNECTION TO PUMP ENCLOSURE HEATER. PROVIDE WEATHERPROOF TOGGLE SWITCH FOR LOCAL CONTROL. LOCATE SWITCH ON NEARBY EXTERIOR WALL.
- 3. PROVIDE 1" CONDUIT FROM ELECTRICAL ROOM TO THE PUMP ENCLOSURE.
- 4. DISCONNECTS SHALL BE MOUNTED ON EXTERIOR WALL WITH CONDUITS FEEDING EQUIPMENT UNDERGROUND.

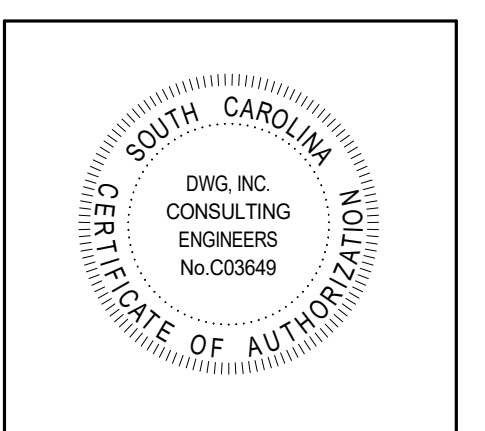

COASTAL CAROLINA UNIVERSITY  
ATHENEUM HALL UNDERGROUND HW REPLACEMENT  
104 INDEPENDENCE DRIVE  
CONWAY, SOUTH CAROLINA 29528  
POWER PLAN

STATE PROJECT NO.:	H17-0111-WW
REV:	1 Addendum 1 03/28/24
DWG JOB NO.:	19162-05
DATE:	01/27/23
DRAWN BY:	MHS
CHECK BY:	MHS/BJJ
SHEET	E101

PLOT DATE: DATE



**DWGI**  
CONSULTING ENGINEERS  
EMPLOYEE OWNED

**COASTAL CAROLINA UNIVERSITY**  
ATHENEUM HALL UNDERGROUND HW REPLACEMENT  
104 INDEPENDENCE DRIVE  
CONWAY, SOUTH CAROLINA 29528  
**MECHANICAL DETAILS**

STATE PROJECT NO.:	H17-0111-WW
REV:	
1	Addendum 1 (03/28/24)
DWG JOB NO.:	19162-05
DATE:	01/27/23
DRAWN BY:	KMM
CHECK BY:	WDB
SHEET	

**M002**

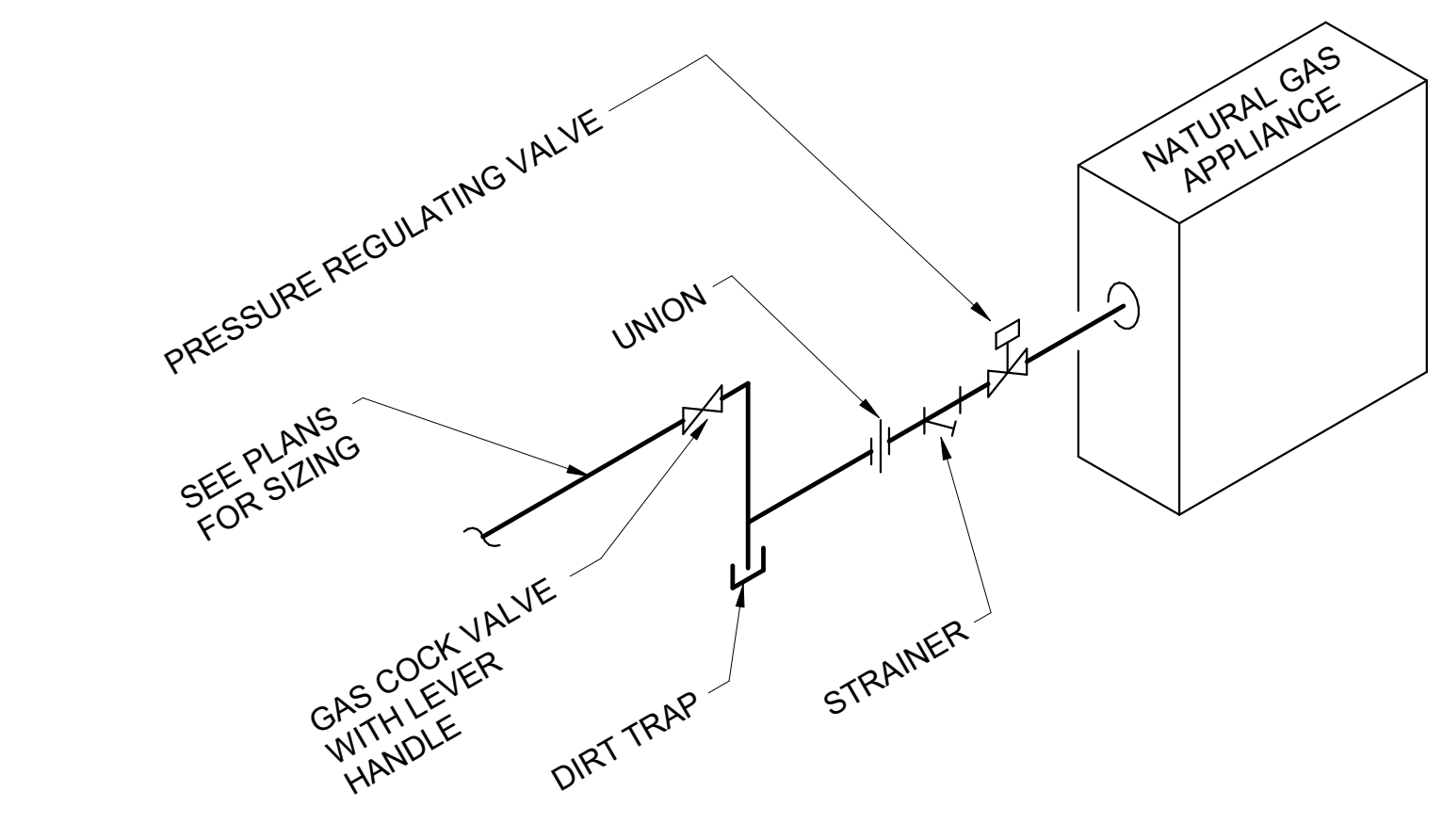

**2 GAS FIRED APPLIANCE CONNECTION DETAIL**  
M002 NOT TO SCALE

MAXIMUM PIPE/TUBING SUPPORT SPACING												
NOM. SIZE	IN.	THRU 3/4	1	1 1/4	1 1/2	2	2 1/2	3	4	5	6	8
PIPE	FT.	7	7	7	9	10	11	12	14	16	17	19
TUBING	FT.	5 FT	6	7	8	8	9	10	12	13	14	16

NOTE: FOR TRAPEZE HANGER TAKE SPACING OF SMALLEST SIZE ON TRAPEZE

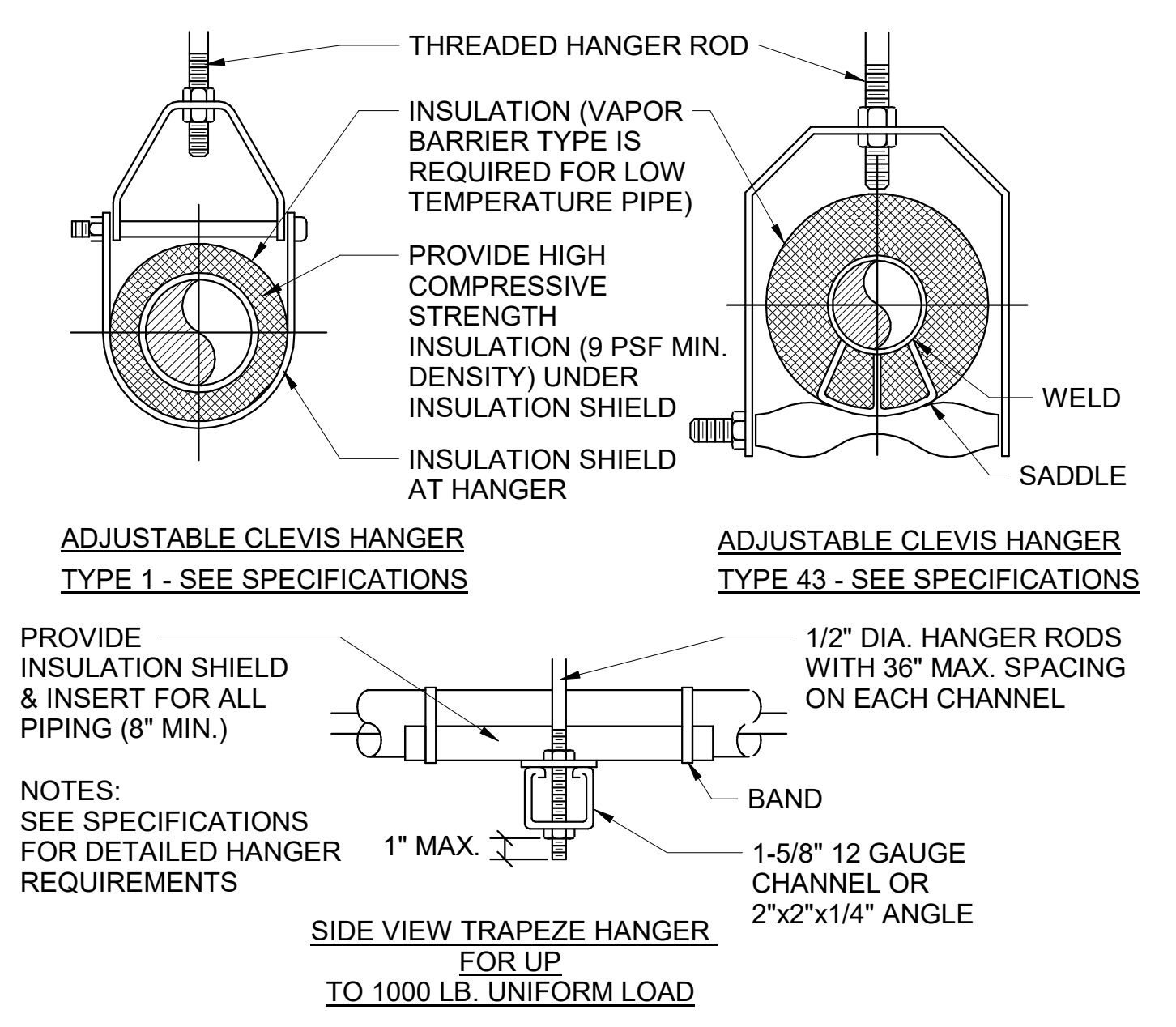

**4. MECHANICAL PIPE SUPPORT DETAIL**  
M002 NOT TO SCALE

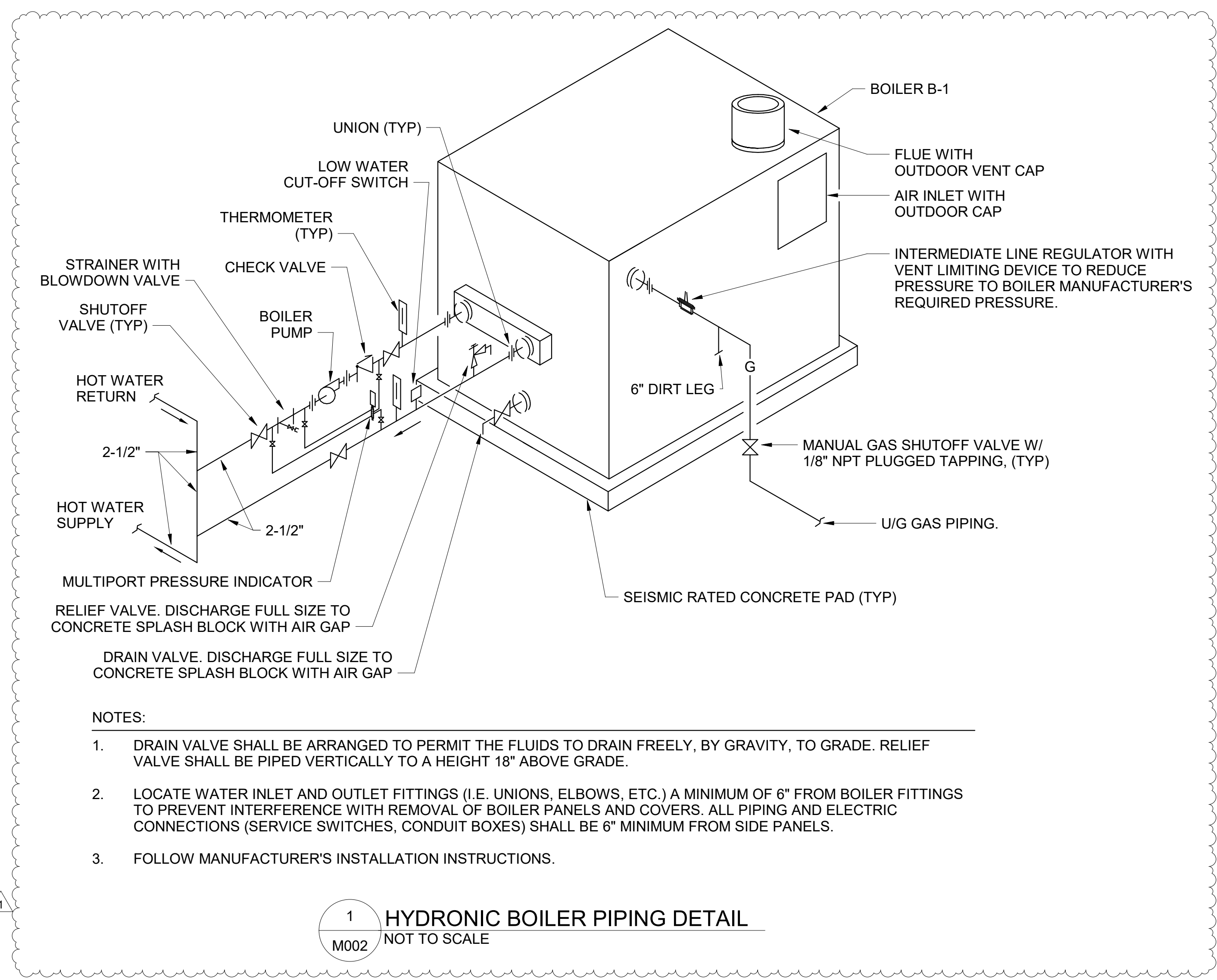

**1 HYDRONIC BOILER PIPING DETAIL**  
M002 NOT TO SCALE

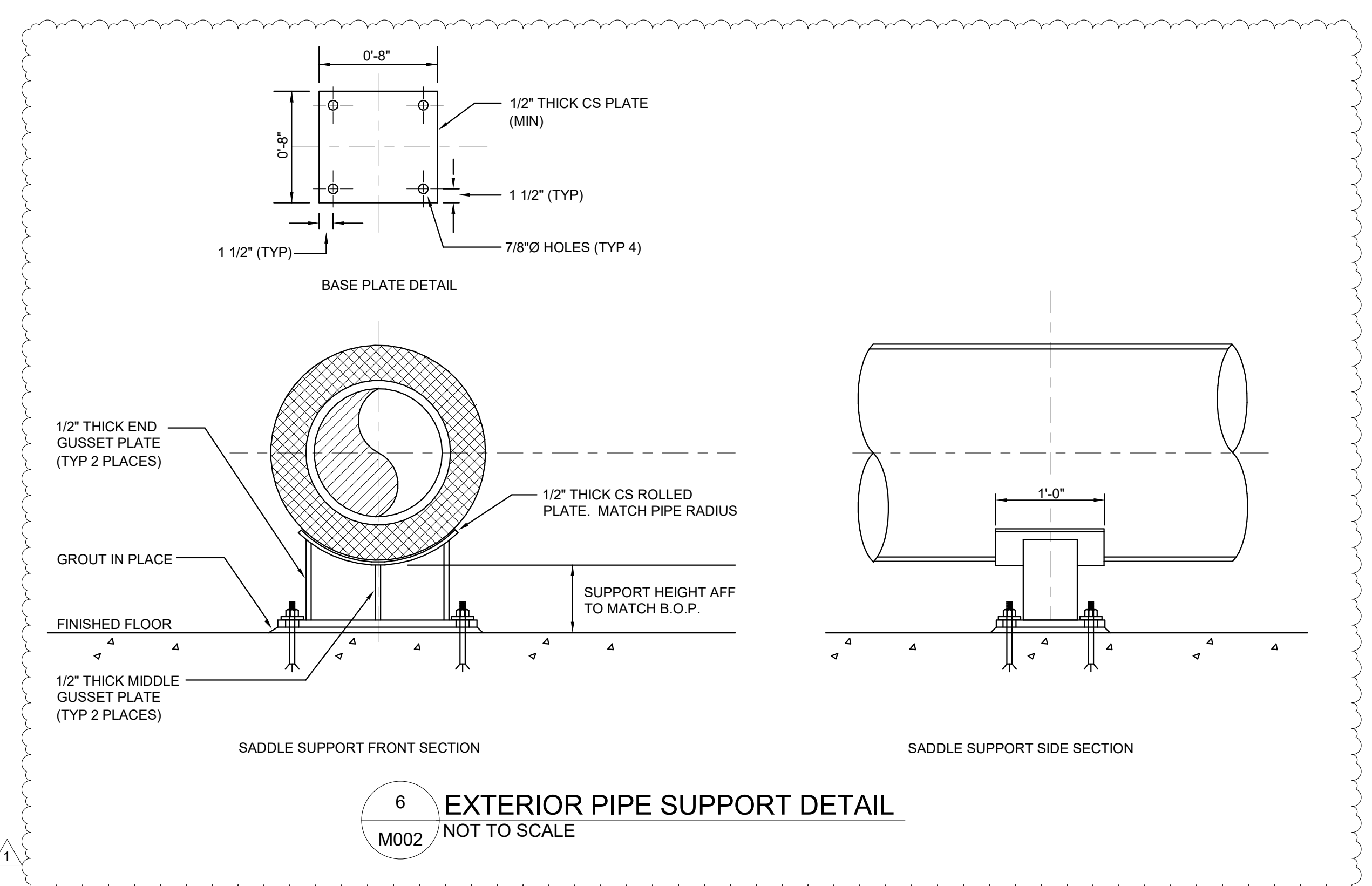

**6 EXTERIOR PIPE SUPPORT DETAIL**  
M002 NOT TO SCALE

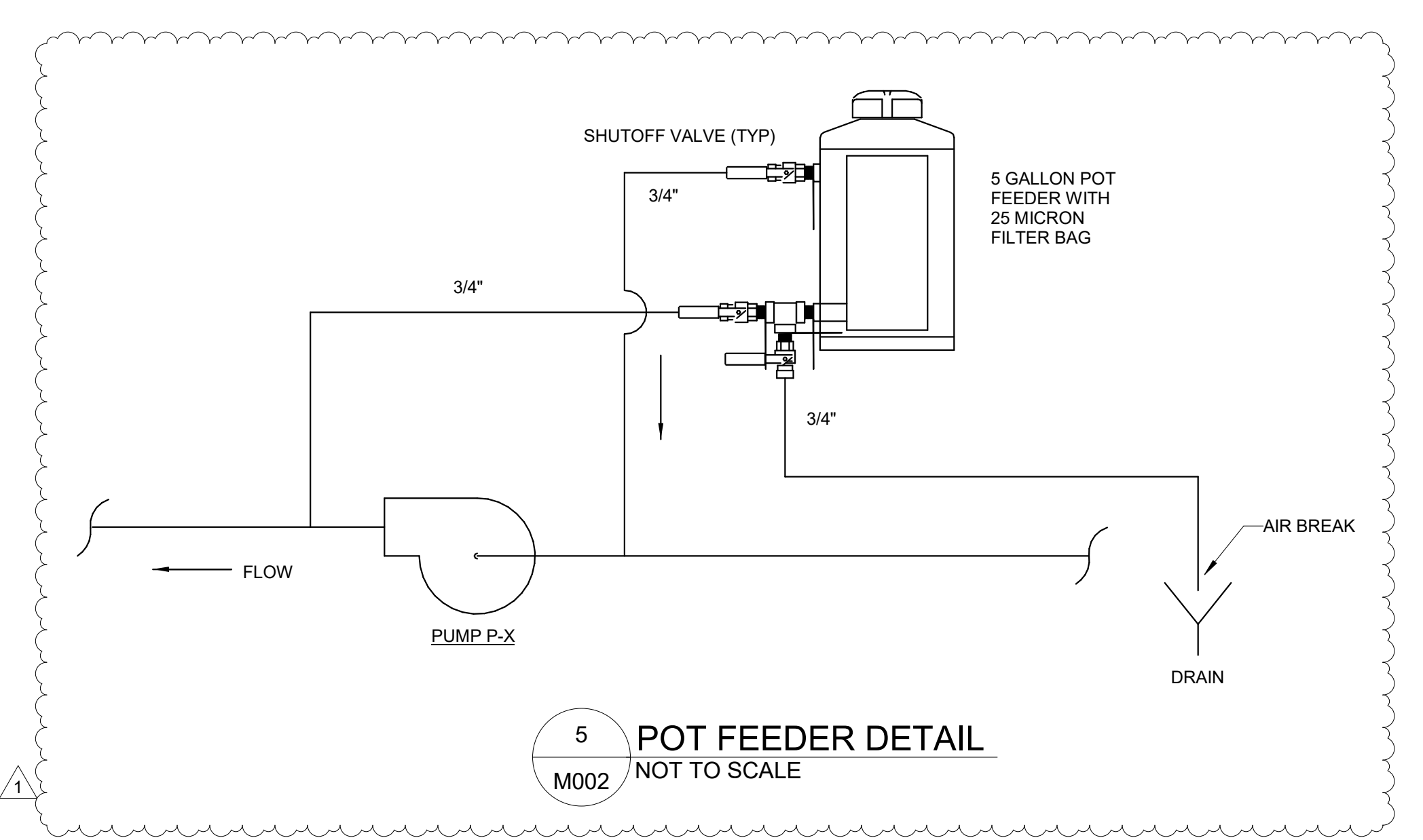

**5 POT FEEDER DETAIL**  
M002 NOT TO SCALE

PLOT DATE: DATE

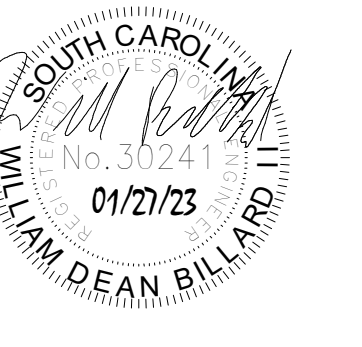
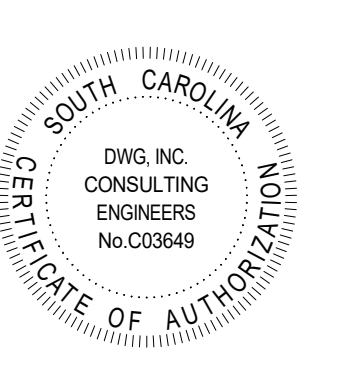

**COASTAL CAROLINA UNIVERSITY**  
 ATHENEUM HALL UNDERGROUND HW REPLACEMENT  
 104 INDEPENDENCE DRIVE  
 CONWAY, SOUTH CAROLINA 29528  
**MECHANICAL FLOW DIAGRAMS**

SYMBOL LEGEND			
ES	EMERGENCY BOILER SHUTOFF SWITCH	TT	THERMOWELL
PI	PRESSURE GAUGE	AAV	AIR ADMITTANCE VALVE
TI	TEMPERATURE GAUGE	RV	RELIEF VALVE
FS	FLOW SENSOR	VFD	VERIABLE FREQUENCY DRIVE

- GENERAL NOTES:**
1. THE WORK FOR THE HVAC CONTROLS SYSTEM WILL BE PERFORMED BY CONTROL MANAGEMENT, INC. UNDER DIRECT CONTRACT WITH COASTAL CAROLINA UNIVERSITY.
  2. SEE SPECIFICATION SECTION 23 09 23 FOR DELINEATION OF WORK.
  3. PROVIDE INSULATION AND JACKETING ON ALL EQUIPMENT.
  4. CONTRACTOR SHALL PROVIDE ALL WELD-OLETS FOR CONTROL DEVICES.
  5. PROVIDE SUFFICIENT QUANTITY OF CHEMICAL TREATMENT FOR VOLUME OF HOT WATER SYSTEM OF THIS BUILDING AND TURN OVER TO OWNER.
  6. HOT WATER SYSTEM SHALL BE VARIABLE SPEED PRIMARY WITH VARIABLE SPEED SECONDARY. BOILER AND PRIMARY LOOP ECM BOILER PUMP SHALL BE CONTROLLED VIA THE BOILER'S INTERNAL MANUFACTURER PROVIDED CONTROL SEQUENCE. SECONDARY HOT WATER LOOP PUMP VARIABLE FREQUENCY DRIVE SHALL BE CONTROLLED BY CMI VIA PRESSURE SENSORS IN THE LOOP.

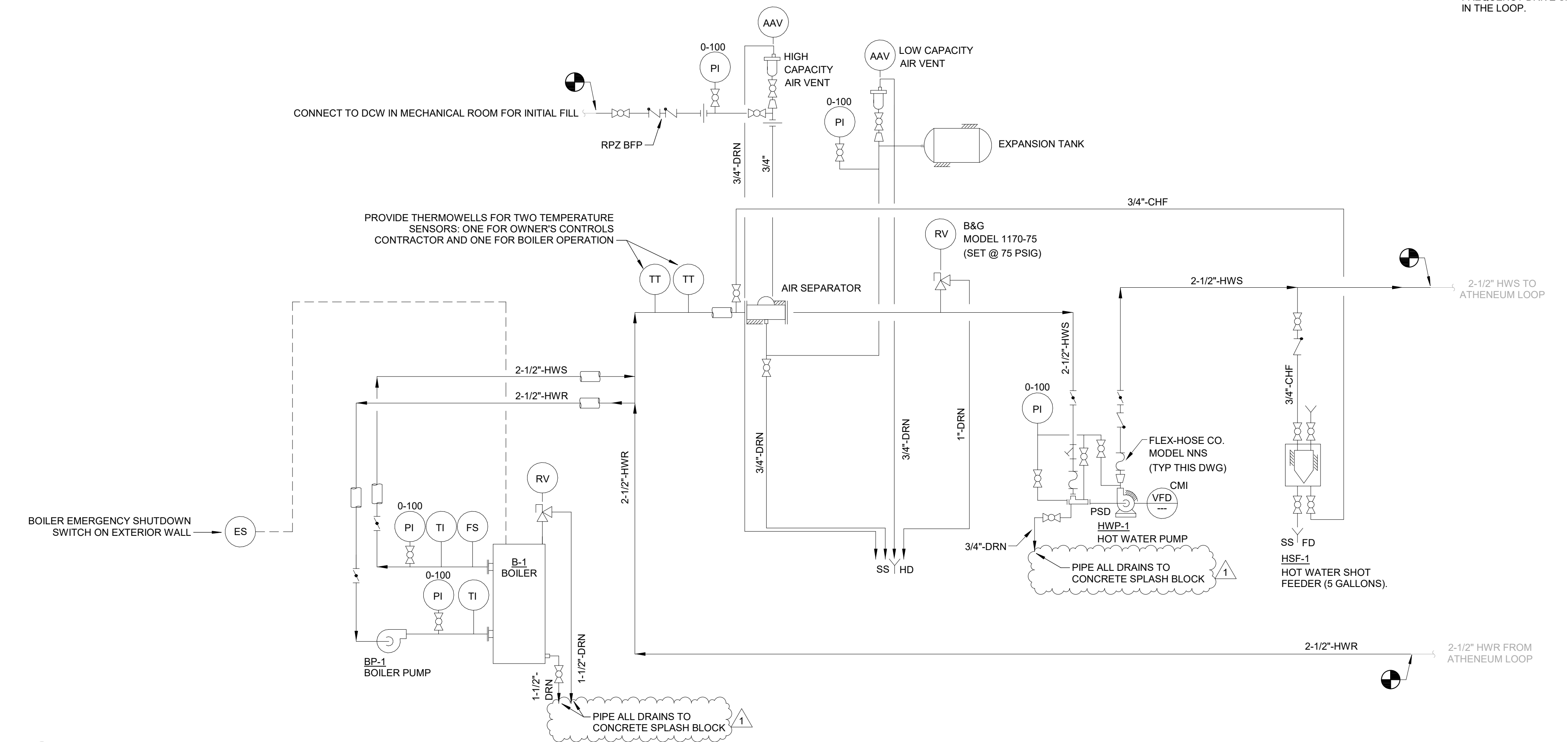

**1 HEATING HOT WATER SYSTEM FLOW DIAGRAM**  
 M003 NOT TO SCALE

STATE PROJECT NO.:		
H17-0111-WW		
REV:		
1	Addendum 1	03/28/24

DWG JOB NO.:	19162-05
DATE:	01/27/23
DRAWN BY:	KMM
CHECK BY:	WDB

SHEET  
**M003**

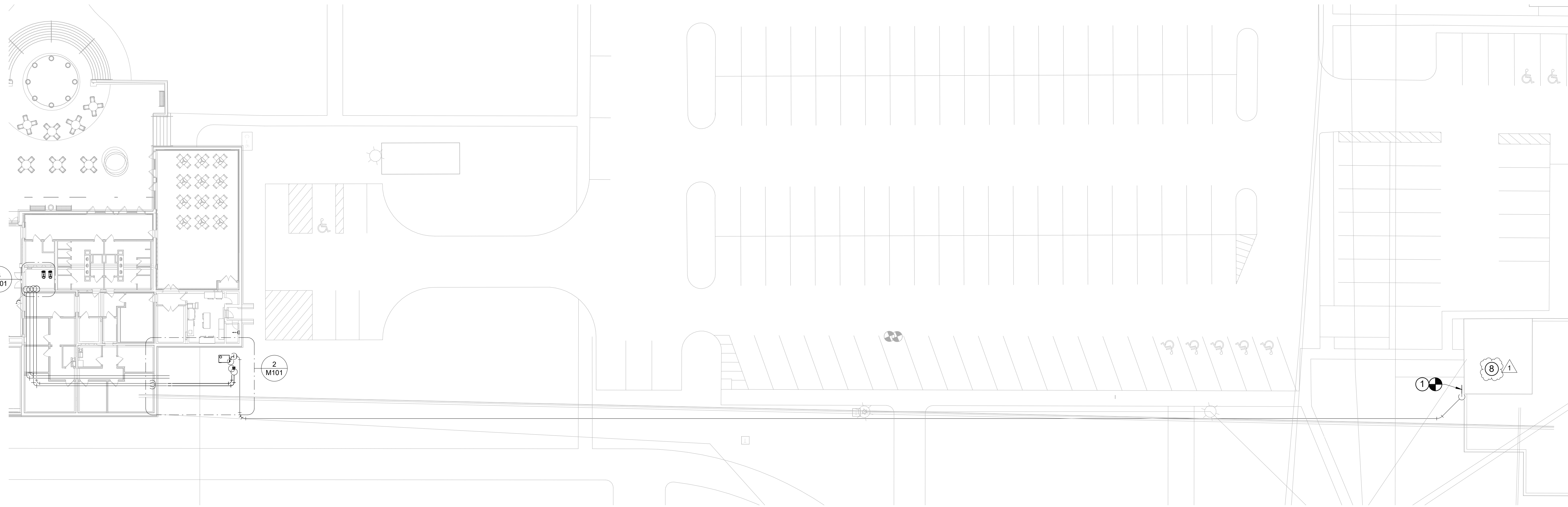

1 MECHANICAL SITE PLAN  
M101 SCALE: 1" = 20'-0"

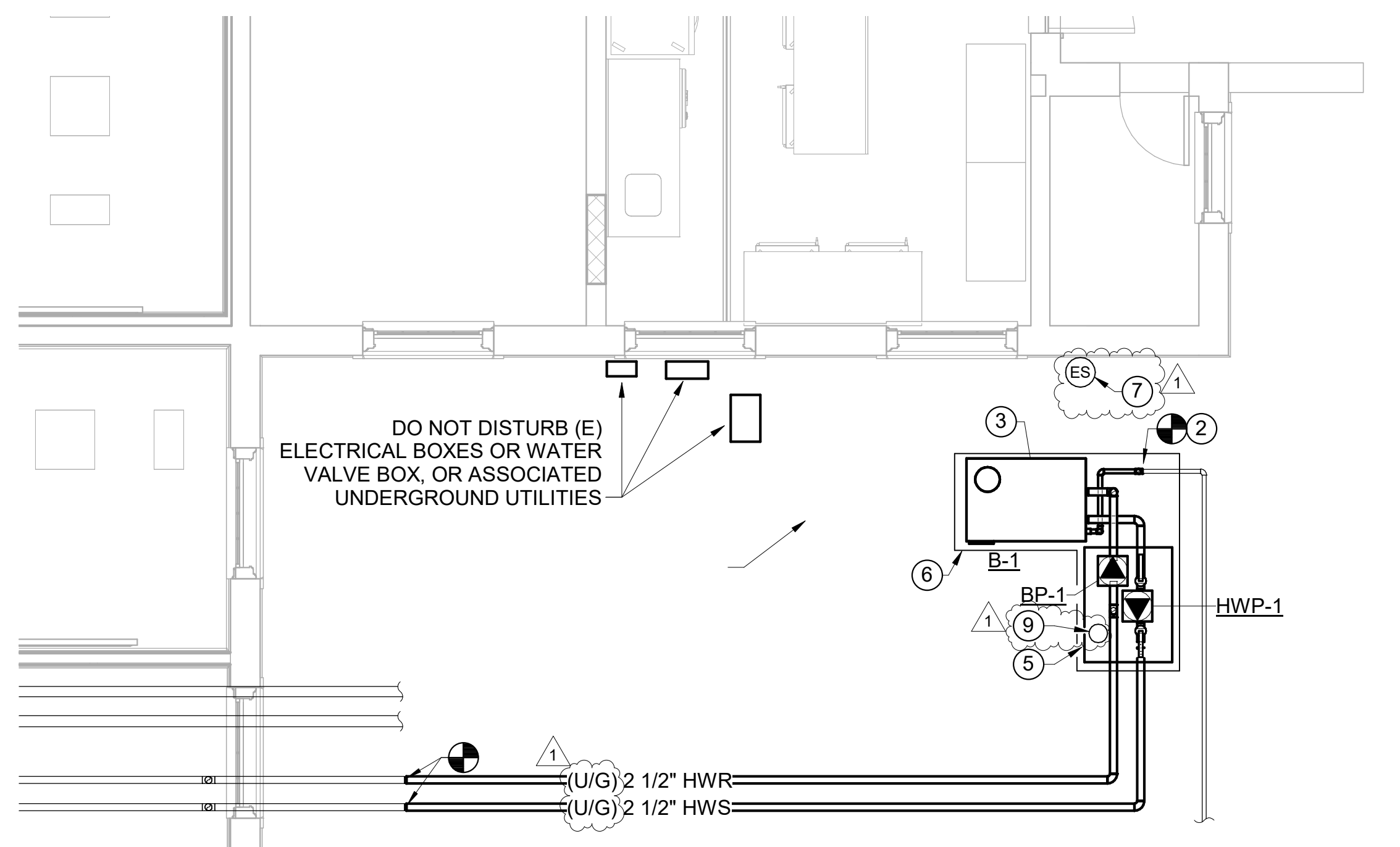

2 ENLARGED EXTERIOR MECHANICAL PIPING PLAN  
M101 SCALE: 1/4" = 1'-0"

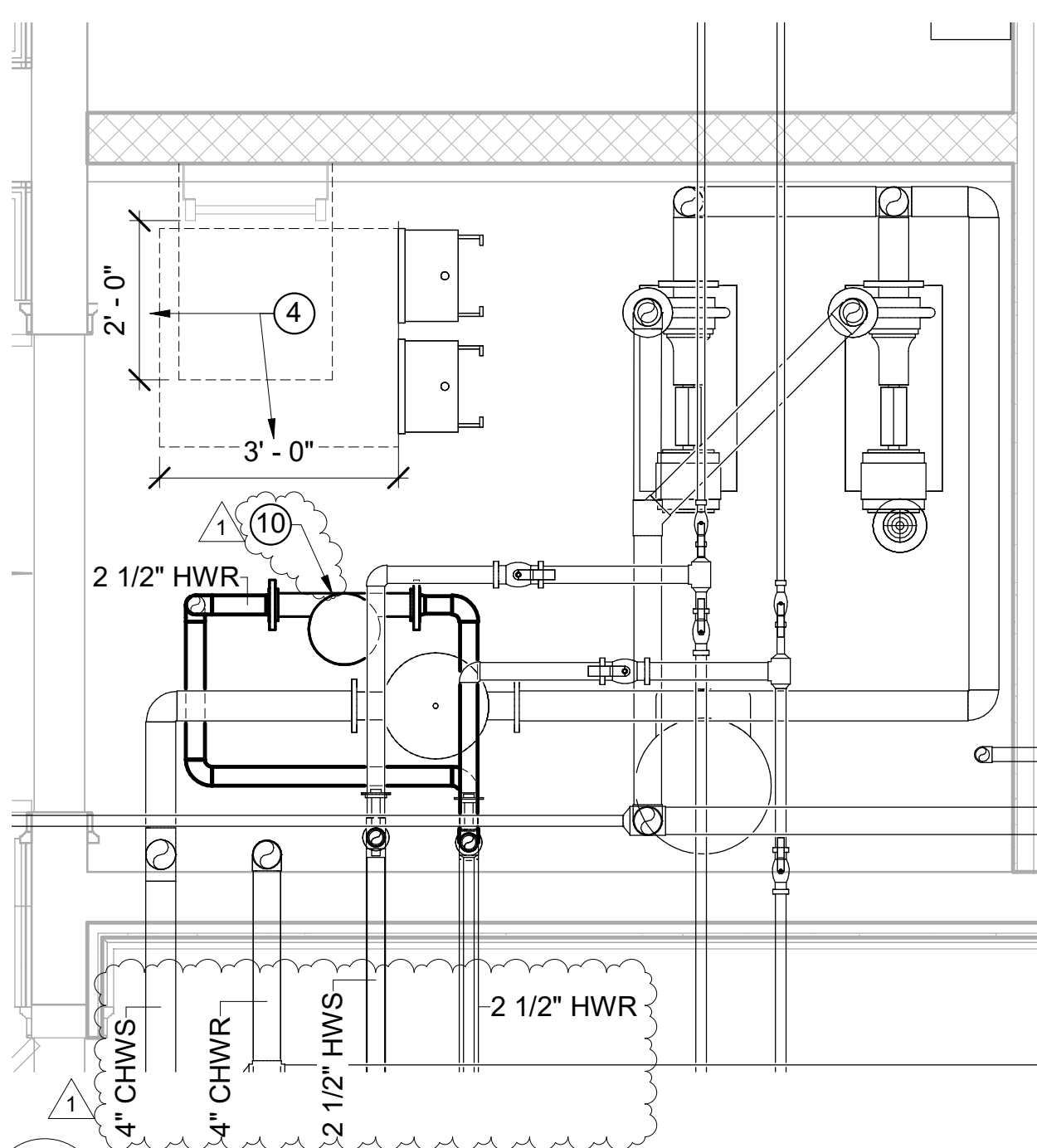

3 ENLARGED MECHANICAL ROOM PIPING PLAN  
M101 SCALE: 1/2" = 1'-0"

GENERAL NOTES

- RENOVATION KEYNOTES**
- 1 CONNECT (E) GAS STUB-UP FROM U/G AT THIS LOCATION TO GAS SUPPLY UPSTREAM OF REGULATOR. COORDINATE SCHEDULE OF UTILITY DOWNTIME AND SHUTDOWN AND START-UP OF EQUIPMENT WITH CCU PROJECT MANAGER.
  - 2 CONNECT (E) GAS STUB-UP FROM U/G AT THIS LOCATION TO RELOCATED BOILER. PROVIDE NEW SHUTOFF VALVE, STRAINER, AND PRESSURE REGULATOR FOR THE BOILER.
  - 3 THE BOILER IS OWNER FURNISHED, HOWEVER THIS CONTRACTOR SHALL BE RESPONSIBLE FOR RELOCATION AND INSTALLATION. THE BOILER IS AN EXISTING BOILER LOCATED AT KEARNS HALL ON CCU CAMPUS. THIS CONTRACTOR SHALL RELOCATE BOILER AND REINSTALL AT THE NEW LOCATION INDICATED. PROVIDE NEW CONCRETE PAD, TO PLACE THE BOILER.
  - 4 MAINTAIN 2'-0" CLEARANCE IN FRONT OF ATTIC ACCESS LADDER. MAINTAIN 3'-0" CLEARANCE IN FRONT OF ELECTRICAL PANELS, DISCONNECTS, AND VFD'S.
  - 5 PROVIDE INSULATED, HEATED, FIBERGLASS FLIP-TOP ENCLOSURE TO PROTECT PUMPS FROM THE ELEMENTS. BASIS OF DESIGN: HUBBELL HOT BOX HL052061052 OR EQUAL.
  - 6 PROVIDE SEISMIC RATED CONCRETE SLAB IN "L" SHAPE TO SUPPORT BOILER AND PUMP ENCLOSURE.
  - 7 BOILER EMERGENCY SHUTDOWN SWITCH ON WALL. REFER TO HEATING HOT WATER SYSTEM FLOW DIAGRAM FOR MORE INFORMATION.
  - 8 CUT AND CAP HOT WATER AND HOT WATER RETURN PIPING AND APPURTENANCES PREVIOUSLY SERVING ATHENEUM HALL WITHIN THE PLANT BUILDING.
  - 9 SHOT FEEDER IN PUMP ENCLOSURE.
  - 10 PROVIDE NEW AIR SEPARATOR AND HORIZONTAL EXPANSION TANK: BELL & GOSSETT ROLAIRTROL R-2.5 AND D-40.

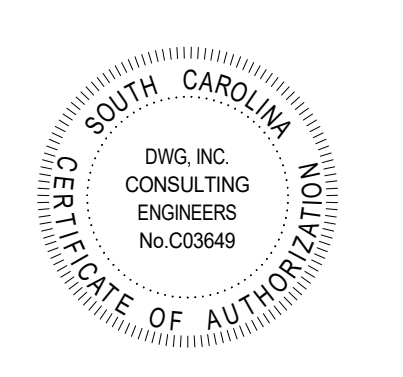

COASTAL CAROLINA UNIVERSITY  
ATHENEUM HALL UNDERGROUND HW REPLACEMENT  
104 INDEPENDENCE DRIVE  
CONWAY, SOUTH CAROLINA 29528  
MECHANICAL PIPING PLAN

STATE PROJECT NO.:	H17-0111-WW
REV:	
1	Addendum 1 03/28/24
DWG JOB NO.:	19162-05
DATE:	01/27/23
DRAWN BY:	KMM
CHECK BY:	WDB
SHEET	

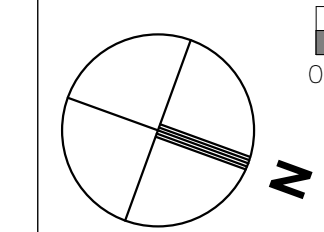
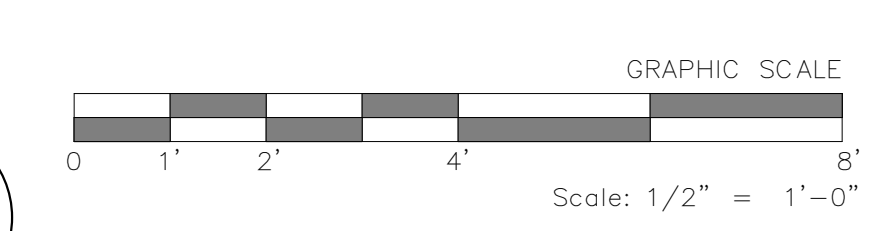
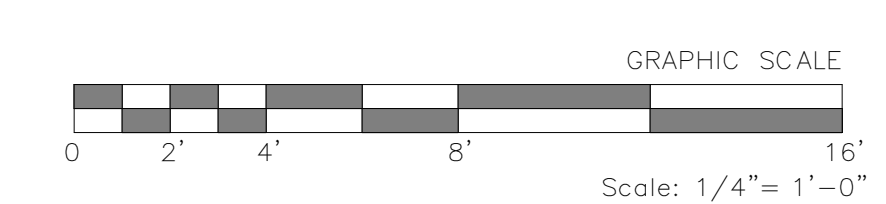
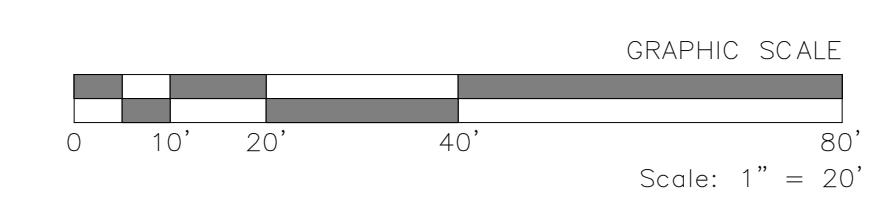

M101

## SECTION 230719 - HVAC PIPING INSULATION

### PART 1 GENERAL

#### 1.01 RELATED DOCUMENTS

- A. Drawings and general provisions of the Contract, including General and Supplementary Conditions and Division 01 Specification Sections, apply to this Section.

#### 1.02 SUMMARY

- A. Section includes insulating the following HVAC piping systems:
  - 1. Heating hot-water piping, indoors and outdoors.

#### 1.03 ACTION SUBMITTALS

- A. Product Data: For each type of product indicated. Include thermal conductivity, water-vapor permeance thickness, and jackets (both factory and field applied if any).
- B. Shop Drawings: Include plans, elevations, sections, details, and attachments to other work.
  - 1. Detail application of protective shields, saddles, and inserts at hangers for each type of insulation and hanger.
  - 2. Detail attachment and covering of heat tracing inside insulation.
  - 3. Detail insulation application at pipe expansion joints for each type of insulation.
  - 4. Detail insulation application at elbows, fittings, flanges, valves, and specialties for each type of insulation.
  - 5. Detail removable insulation at piping specialties.
  - 6. Detail application of field-applied jackets.
  - 7. Detail application at linkages of control devices.

#### 1.04 INFORMATIONAL SUBMITTALS

- A. Qualification Data: For qualified Installer.
- B. Material Test Reports: From a qualified testing agency acceptable to authorities having jurisdiction indicating, interpreting, and certifying test results for compliance of insulation materials, sealers, attachments, cements, and jackets, with requirements indicated. Include dates of tests and test methods employed.
- C. Field quality-control reports.



#### 1.05 QUALITY ASSURANCE

- A. Installer Qualifications: Skilled mechanics who have successfully completed an apprenticeship program or another craft training program certified by the Department of Labor, Bureau of Apprenticeship and Training.
- B. Surface-Burning Characteristics: For insulation and related materials, as determined by testing identical products according to ASTM E 84, by a testing and inspecting agency acceptable to authorities having jurisdiction. Factory label insulation and jacket materials and adhesive, mastic, tapes, and cement material containers, with appropriate markings of applicable testing agency.
  - 1. Flame-spread index of 25 or less, and smoke-developed index of 50 or less.

#### 1.06 DELIVERY, STORAGE, AND HANDLING

- A. Packaging: Insulation material containers shall be marked by manufacturer with appropriate ASTM standard designation, type and grade, and maximum use temperature.

#### 1.07 COORDINATION

- A. Coordinate sizes and locations of supports, hangers, and insulation shields specified in Section 230529 "Hangers and Supports for HVAC Piping and Equipment."
- B. Coordinate clearance requirements with piping Installer for piping insulation application. Before preparing piping Shop Drawings, establish and maintain clearance requirements for installation of insulation and field-applied jackets and finishes and for space required for maintenance.
- C. Coordinate installation and testing of heat tracing.

#### 1.08 SCHEDULING

- A. Schedule insulation application after pressure testing systems and, where required, after installing and testing heat tracing. Insulation application may begin on segments that have satisfactory test results.
- B. Complete installation and concealment of plastic materials as rapidly as possible in each area of construction.

### PART 2 PRODUCTS

#### 2.01 INSULATION MATERIALS

- A. Comply with requirements in "Piping Insulation Schedule, General," "Indoor Piping Insulation Schedule," and "Outdoor, Aboveground Piping Insulation Schedule" articles for where insulating materials shall be applied.

- B. Products shall not contain asbestos, lead, mercury, or mercury compounds.
- C. Products that come in contact with stainless steel shall have a leachable chloride content of less than 50 ppm when tested according to ASTM C 871.
- D. Insulation materials for use on austenitic stainless steel shall be qualified as acceptable according to ASTM C 795.
- E. Foam insulation materials shall not use CFC or HCFC blowing agents in the manufacturing process.
- F. Cellular Glass: Inorganic, incombustible, foamed or cellulated glass with annealed, rigid, hermetically sealed cells. Factory-applied jacket requirements are specified in "Factory-Applied Jackets" Article.
  - 1. Minimum thermal performance: 0.21 Btu-in/hr-ft<sup>2</sup>-F at mean rating temperature of 75 deg F.
  - 2. Block Insulation: ASTM C 552, Type I.
  - 3. Special-Shaped Insulation: ASTM C 552, Type III.
  - 4. Board Insulation: ASTM C 552, Type IV.
  - 5. Preformed Pipe Insulation without Jacket: Comply with ASTM C 552, Type II, Class 1.
  - 6. Preformed Pipe Insulation with Factory-Applied ASJ, ASJ-SSL: Comply with ASTM C 552, Type II, Class 2.
  - 7. Factory fabricate shapes according to ASTM C 450 and ASTM C 585.
- G. Mineral-Fiber, Preformed Pipe Insulation:
  - 1. Type I, 850 deg F Materials: Mineral or glass fibers bonded with a thermosetting resin. Comply with ASTM C 547, Type I, Grade A, with factory-applied ASJ-SSL. Factory-applied jacket requirements are specified in "Factory-Applied Jackets" Article.
  - 2. Minimum thermal performance: 0.23 Btu-in/hr-ft<sup>2</sup>-F at mean rating temperature of 75 deg F.
- H. Mineral-Fiber, Pipe and Tank Insulation: Mineral or glass fibers bonded with a thermosetting resin. Semirigid board material with factory-applied ASJ complying with ASTM C 1393, Type II or Type IIIA Category 2, or with properties similar to ASTM C 612, Type IB. Nominal density is 2.5 lb/cu. ft. or more. Thermal conductivity (k-value) at 100 deg F is 0.29 Btu x in./h x sq. ft. x deg F or less. Factory-applied jacket requirements are specified in "Factory-Applied Jackets" Article.

## 2.02 ADHESIVES

- A. Materials shall be compatible with insulation materials, jackets, and substrates and for bonding insulation to itself and to surfaces to be insulated unless otherwise indicated.
- B. Cellular-Glass Adhesive: Two-component, thermosetting urethane adhesive containing no flammable solvents, with a service temperature range of minus 100 to plus 200 deg F.

1. For all interior (inside the weatherproofing of the building) adhesives applied on site, provide manufacturer documentation that the product meets the VOC content limits SCAQMD Rule 1168.
  2. Provide documentation the product has been tested according to CDPH Standard Method v1.2 and complies with the VOC limits per Section 016116 VOLATILE ORGANIC COMPOUND (VOC) CONTENT RESTRICTIONS.
- C. Mineral-Fiber Adhesive: Comply with MIL-A-3316C, Class 2, Grade A.
1. For all interior (inside the weatherproofing of the building) adhesives applied on site, provide manufacturer documentation that the product meets the VOC content limits SCAQMD Rule 1168.
  2. Provide documentation the product has been tested according to CDPH Standard Method v1.2 and complies with the VOC limits per Section 016116 VOLATILE ORGANIC COMPOUND (VOC) CONTENT RESTRICTIONS.
- D. ASJ Adhesive, and FSK Adhesive: Comply with MIL-A-3316C, Class 2, Grade A for bonding insulation jacket lap seams and joints.
1. For all interior (inside the weatherproofing of the building) adhesives applied on site, provide manufacturer documentation that the product meets the VOC content limits SCAQMD Rule 1168.
  2. Provide documentation the product has been tested according to CDPH Standard Method v1.2 and complies with the VOC limits per Section 016116 VOLATILE ORGANIC COMPOUND (VOC) CONTENT RESTRICTIONS.
- E. PVC Jacket Adhesive: Compatible with PVC jacket.
1. For all interior (inside the weatherproofing of the building) adhesives applied on site, provide manufacturer documentation that the product meets the VOC content limits SCAQMD Rule 1168.
  2. Provide documentation the product has been tested according to CDPH Standard Method v1.2 and complies with the VOC limits per Section 016116 VOLATILE ORGANIC COMPOUND (VOC) CONTENT RESTRICTIONS.
- 2.03 MASTICS
- A. Materials shall be compatible with insulation materials, jackets, and substrates; comply with MIL-PRF-19565C, Type II.
1. For all interior (inside the weatherproofing of the building) mastics applied on site, provide manufacturer documentation that the product meets the VOC content limits SCAQMD Rule 1168 and the emissions testing requirements per Section 016116 VOLATILE ORGANIC COMPOUND (VOC) CONTENT RESTRICTIONS.
- B. Vapor-Barrier Mastic: Water based; suitable for indoor use on below-ambient services.
1. Water-Vapor Permeance: ASTM E 96/E 96M, Procedure B, 0.013 perm at 43-mil dry film thickness.
  2. Service Temperature Range: Minus 20 to plus 180 deg F.

3. Solids Content: ASTM D 1644, 58 percent by volume and 70 percent by weight.
  4. Color: White.
- C. Vapor-Barrier Mastic: Solvent based; suitable for indoor use on below-ambient services.
1. Water-Vapor Permeance: ASTM F 1249, 0.05 perm at 35-mil dry film thickness.
  2. Service Temperature Range: 0 to 180 deg F.
  3. Solids Content: ASTM D 1644, 44 percent by volume and 62 percent by weight.
  4. Color: White.
- D. Vapor-Barrier Mastic: Solvent based; suitable for outdoor use on below-ambient services.
1. Water-Vapor Permeance: ASTM F 1249, 0.05 perm at 30-mil dry film thickness.
  2. Service Temperature Range: Minus 50 to plus 220 deg F.
  3. Solids Content: ASTM D 1644, 33 percent by volume and 46 percent by weight.
  4. Color: White.
- E. Breather Mastic: Water based; suitable for indoor and outdoor use on above-ambient services.
1. Water-Vapor Permeance: ASTM F 1249, 1.8 perms at 0.0625-inch dry film thickness.
  2. Service Temperature Range: Minus 20 to plus 180 deg F.
  3. Solids Content: 60 percent by volume and 66 percent by weight.
  4. Color: White.

#### 2.04 LAGGING ADHESIVES

- A. Description: Comply with MIL-A-3316C, Class I, Grade A and shall be compatible with insulation materials, jackets, and substrates.
1. For all interior (inside the weatherproofing of the building) lagging adhesives applied on site, provide manufacturer documentation that the product meets the VOC content limits SCAQMD Rule 1168.
  2. Provide documentation the product has been tested according to CDPH Standard Method v1.2 and complies with the VOC limits per Section 016116 VOLATILE ORGANIC COMPOUND (VOC) CONTENT RESTRICTIONS.
  3. Fire-resistant, water-based lagging adhesive and coating for use indoors to adhere fire-resistant lagging cloths over pipe insulation.
  4. Service Temperature Range: 0 to plus 180 deg F.
  5. Color: White.

#### 2.05 SEALANTS

- A. Joint Sealants:
1. Materials shall be compatible with insulation materials, jackets, and substrates.
  2. Service Temperature Range: Minus 100 to plus 300 deg F.
  3. Color: White or gray.

4. For all interior (inside the weatherproofing of the building) sealants applied on site, provide manufacturer documentation that the product meets the VOC content limits SCAQMD Rule 1168.
5. Provide documentation the product has been tested according to CDPH Standard Method v1.2 and complies with the VOC limits per Section 016116 VOLATILE ORGANIC COMPOUND (VOC) CONTENT RESTRICTIONS.

B. FSK and Metal Jacket Flashing Sealants:

1. Materials shall be compatible with insulation materials, jackets, and substrates.
2. Service Temperature Range: Minus 40 to plus 250 deg F.
3. Color: Aluminum.
4. For all interior (inside the weatherproofing of the building) sealants applied on site, provide manufacturer documentation that the product meets the VOC content limits SCAQMD Rule 1168.
5. Provide documentation the product has been tested according to CDPH Standard Method v1.2 and complies with the VOC limits per Section 016116 VOLATILE ORGANIC COMPOUND (VOC) CONTENT RESTRICTIONS.

C. ASJ Flashing Sealants and PVC Jacket Flashing Sealants:

1. Materials shall be compatible with insulation materials, jackets, and substrates.
2. Service Temperature Range: Minus 40 to plus 250 deg F.
3. Color: White.
4. For all interior (inside the weatherproofing of the building) sealants applied on site, provide manufacturer documentation that the product meets the VOC content limits SCAQMD Rule 1168.
5. Provide documentation the product has been tested according to CDPH Standard Method v1.2 and complies with the VOC limits per Section 016116 VOLATILE ORGANIC COMPOUND (VOC) CONTENT RESTRICTIONS.

## 2.06 FACTORY-APPLIED JACKETS

A. Insulation system schedules indicate factory-applied jackets on various applications. When factory-applied jackets are indicated, comply with the following:

1. ASJ: White, kraft-paper, fiberglass-reinforced scrim with aluminum-foil backing; complying with ASTM C 1136, Type I.
2. ASJ-SSL: ASJ with self-sealing, pressure-sensitive, acrylic-based adhesive covered by a removable protective strip; complying with ASTM C 1136, Type I.

## 2.07 FIELD-APPLIED JACKETS

- A. Field-applied jackets shall comply with ASTM C 921, Type I, unless otherwise indicated.
- B. PVC Jacket: High-impact-resistant, UV-resistant PVC complying with ASTM D 1784, Class 16354-C; thickness as scheduled; roll stock ready for shop or field cutting and forming. Thickness is indicated in field-applied jacket schedules.

1. Adhesive: As recommended by jacket material manufacturer.
2. Color: White.
3. Factory-fabricated fitting covers to match jacket if available; otherwise, field fabricate.
  - a. Shapes: 45- and 90-degree, short- and long-radius elbows, tees, valves, flanges, unions, reducers, end caps, soil-pipe hubs, traps, mechanical joints, and P-trap and supply covers for lavatories.

C. Metal Jacket:

1. Aluminum Jacket: Comply with ASTM B 209, Alloy 3003, 3005, 3105, or 5005, Temper H-14.
  - a. Sheet and roll stock ready for shop or field sizing.
  - b. Finish and thickness are indicated in field-applied jacket schedules.
  - c. Moisture Barrier for Indoor Applications: 1-mil- thick, heat-bonded polyethylene and kraft paper
  - d. Moisture Barrier for Outdoor Applications: 3-mil- thick, heat-bonded polyethylene and kraft paper.
  - e. Factory-Fabricated Fitting Covers:
    - 1) Same material, finish, and thickness as jacket.
    - 2) Preformed 2-piece or gore, 45- and 90-degree, short- and long-radius elbows.
    - 3) Tee covers.
    - 4) Flange and union covers.
    - 5) End caps.
    - 6) Beveled collars.
    - 7) Valve covers.
    - 8) Field fabricate fitting covers only if factory-fabricated fitting covers are not available.

2.08 TAPES

- A. ASJ Tape: White vapor-retarder tape matching factory-applied jacket with acrylic adhesive, complying with ASTM C 1136.
  1. Width: 3 inches.
  2. Thickness: 11.5 mils.
  3. Adhesion: 90 ounces force/inch in width.
  4. Elongation: 2 percent.
  5. Tensile Strength: 40 lbf/inch in width.
  6. ASJ Tape Disks and Squares: Precut disks or squares of ASJ tape.
- B. PVC Tape: White vapor-retarder tape matching field-applied PVC jacket with acrylic adhesive; suitable for indoor and outdoor applications.
  1. Width: 2 inches.
  2. Thickness: 6 mils.
  3. Adhesion: 64 ounces force/inch in width.

4. Elongation: 500 percent.
5. Tensile Strength: 18 lbf/inch in width.

## 2.09 SECUREMENTS

### A. Bands:

1. Stainless Steel: ASTM A 167 or ASTM A 240/A 240M, Type 304 or Type 316; 0.015 inch thick, 1/2 inch wide with wing seal or closed seal.
2. Aluminum: ASTM B 209, Alloy 3003, 3005, 3105, or 5005; Temper H-14, 0.020 inch thick, 1/2 inch wide with wing seal or closed seal.
3. Springs: Twin spring set constructed of stainless steel with ends flat and slotted to accept metal bands. Spring size determined by manufacturer for application.

### B. Staples: Outward-clinching insulation staples, nominal 3/4-inch- wide, stainless steel or Monel.

## PART 3 EXECUTION

### 3.01 EXAMINATION

- #### A. Examine substrates and conditions for compliance with requirements for installation tolerances and other conditions affecting performance of insulation application.
1. Verify that systems to be insulated have been tested and are free of defects.
  2. Verify that surfaces to be insulated are clean and dry.
  3. Proceed with installation only after unsatisfactory conditions have been corrected.

### 3.02 PREPARATION

- #### A. Surface Preparation: Clean and dry surfaces to receive insulation. Remove materials that will adversely affect insulation application.
- #### B. Surface Preparation: Clean and prepare surfaces to be insulated. Before insulating, apply a corrosion coating to insulated surfaces as follows:
1. Stainless Steel: Coat 300 series stainless steel with an epoxy primer 5 mils thick and an epoxy finish 5 mils thick if operating in a temperature range between 140 and 300 deg F. Consult coating manufacturer for appropriate coating materials and application methods for operating temperature range.
  2. Carbon Steel: Coat carbon steel operating at a service temperature between 32 and 300 deg F with an epoxy coating. Consult coating manufacturer for appropriate coating materials and application methods for operating temperature range.
- #### C. Coordinate insulation installation with the trade installing heat tracing. Comply with requirements for heat tracing that apply to insulation.

- D. Mix insulating cements with clean potable water; if insulating cements are to be in contact with stainless-steel surfaces, use demineralized water.

### 3.03 GENERAL INSTALLATION REQUIREMENTS

- A. Install insulation materials, accessories, and finishes with smooth, straight, and even surfaces; free of voids throughout the length of piping including fittings, valves, and specialties.
- B. Install insulation materials, forms, vapor barriers or retarders, jackets, and thicknesses required for each item of pipe system as specified in insulation system schedules.
- C. Install accessories compatible with insulation materials and suitable for the service. Install accessories that do not corrode, soften, or otherwise attack insulation or jacket in either wet or dry state.
- D. Install insulation with longitudinal seams at top and bottom of horizontal runs.
- E. Install multiple layers of insulation with longitudinal and end seams staggered.
- F. Do not weld brackets, clips, or other attachment devices to piping, fittings, and specialties.
- G. Keep insulation materials dry during application and finishing.
- H. Install insulation with tight longitudinal seams and end joints. Bond seams and joints with adhesive recommended by insulation material manufacturer.
- I. Install insulation with least number of joints practical.
- J. Where vapor barrier is indicated, seal joints, seams, and penetrations in insulation at hangers, supports, anchors, and other projections with vapor-barrier mastic.
  - 1. Install insulation continuously through hangers and around anchor attachments.
  - 2. For insulation application where vapor barriers are indicated, extend insulation on anchor legs from point of attachment to supported item to point of attachment to structure. Taper and seal ends at attachment to structure with vapor-barrier mastic.
  - 3. Install insert materials and install insulation to tightly join the insert. Seal insulation to insulation inserts with adhesive or sealing compound recommended by insulation material manufacturer.
  - 4. Cover inserts with jacket material matching adjacent pipe insulation. Install shields over jacket, arranged to protect jacket from tear or puncture by hanger, support, and shield.
- K. Apply adhesives, mastics, and sealants at manufacturer's recommended coverage rate and wet and dry film thicknesses.
- L. Install insulation with factory-applied jackets as follows:
  - 1. Draw jacket tight and smooth.
  - 2. Cover circumferential joints with 3-inch- wide strips, of same material as insulation jacket. Secure strips with adhesive and outward clinching staples along both edges of strip, spaced 4 inches o.c.



3. Overlap jacket longitudinal seams at least 1-1/2 inches. Install insulation with longitudinal seams at bottom of pipe. Clean and dry surface to receive self-sealing lap. Staple laps with outward clinching staples along edge at 2 inches o.c.
    - a. For below-ambient services, apply vapor-barrier mastic over staples.
  4. Cover joints and seams with tape, according to insulation material manufacturer's written instructions, to maintain vapor seal.
  5. Where vapor barriers are indicated, apply vapor-barrier mastic on seams and joints and at ends adjacent to pipe flanges and fittings.
- M. Cut insulation in a manner to avoid compressing insulation more than 75 percent of its nominal thickness.
- N. Finish installation with systems at operating conditions. Repair joint separations and cracking due to thermal movement.
- O. Repair damaged insulation facings by applying same facing material over damaged areas. Extend patches at least 4 inches beyond damaged areas. Adhere, staple, and seal patches similar to butt joints.
- P. For above-ambient services, do not install insulation to the following:
1. Vibration-control devices.
  2. Testing agency labels and stamps.
  3. Nameplates and data plates.
  4. Manholes.
  5. Handholes.
  6. Cleanouts.

### 3.04 PENETRATIONS

- A. Insulation Installation at Roof Penetrations: Install insulation continuously through roof penetrations.
1. Seal penetrations with flashing sealant.
  2. For applications requiring only indoor insulation, terminate insulation above roof surface and seal with joint sealant. For applications requiring indoor and outdoor insulation, install insulation for outdoor applications tightly joined to indoor insulation ends. Seal joint with joint sealant.
  3. Extend jacket of outdoor insulation outside roof flashing at least 2 inches below top of roof flashing.
  4. Seal jacket to roof flashing with flashing sealant.
- B. Insulation Installation at Aboveground Exterior Wall Penetrations: Install insulation continuously through wall penetrations.
1. Seal penetrations with flashing sealant.
  2. For applications requiring only indoor insulation, terminate insulation inside wall surface and seal with joint sealant. For applications requiring indoor and outdoor insulation,

- install insulation for outdoor applications tightly joined to indoor insulation ends. Seal joint with joint sealant.
3. Extend jacket of outdoor insulation outside wall flashing and overlap wall flashing at least 2 inches.
  4. Seal jacket to wall flashing with flashing sealant.
- C. Insulation Installation at Interior Wall and Partition Penetrations (That Are Not Fire Rated): Install insulation continuously through walls and partitions.
- D. Insulation Installation at Fire-Rated Wall and Partition Penetrations: Install insulation continuously through penetrations of fire-rated walls and partitions.
1. Comply with requirements in Section 078413 "Penetration Firestopping" for firestopping and fire-resistant joint sealers.
- E. Insulation Installation at Floor Penetrations:
1. Pipe: Install insulation continuously through floor penetrations.
  2. Seal penetrations through fire-rated assemblies. Comply with requirements in Section 078413 "Penetration Firestopping."

### 3.05 GENERAL PIPE INSULATION INSTALLATION

- A. Requirements in this article generally apply to all insulation materials except where more specific requirements are specified in various pipe insulation material installation articles.
- B. Insulation Installation on Fittings, Valves, Strainers, Flanges, and Unions:
1. Install insulation over fittings, valves, strainers, flanges, unions, and other specialties with continuous thermal and vapor-retarder integrity unless otherwise indicated.
  2. Insulate pipe elbows using preformed fitting insulation or mitered fittings made from same material and density as adjacent pipe insulation. Each piece shall be butted tightly against adjoining piece and bonded with adhesive. Fill joints, seams, voids, and irregular surfaces with insulating cement finished to a smooth, hard, and uniform contour that is uniform with adjoining pipe insulation.
  3. Insulate tee fittings with preformed fitting insulation or sectional pipe insulation of same material and thickness as used for adjacent pipe. Cut sectional pipe insulation to fit. Butt each section closely to the next and hold in place with tie wire. Bond pieces with adhesive.
  4. Insulate valves using preformed fitting insulation or sectional pipe insulation of same material, density, and thickness as used for adjacent pipe. Overlap adjoining pipe insulation by not less than two times the thickness of pipe insulation, or one pipe diameter, whichever is thicker. For valves, insulate up to and including the bonnets, valve stuffing-box studs, bolts, and nuts. Fill joints, seams, and irregular surfaces with insulating cement.
  5. Insulate strainers using preformed fitting insulation or sectional pipe insulation of same material, density, and thickness as used for adjacent pipe. Overlap adjoining pipe insulation by not less than two times the thickness of pipe insulation, or one pipe diameter, whichever is thicker. Fill joints, seams, and irregular surfaces with insulating cement. Insulate strainers so strainer basket flange or plug can be easily removed and

- replaced without damaging the insulation and jacket. Provide a removable reusable insulation cover. For below-ambient services, provide a design that maintains vapor barrier.
6. Insulate flanges and unions using a section of oversized preformed pipe insulation. Overlap adjoining pipe insulation by not less than two times the thickness of pipe insulation, or one pipe diameter, whichever is thicker.
  7. Cover segmented insulated surfaces with a layer of finishing cement and coat with a mastic. Install vapor-barrier mastic for below-ambient services and a breather mastic for above-ambient services. Reinforce the mastic with fabric-reinforcing mesh. Trowel the mastic to a smooth and well-shaped contour.
  8. For services not specified to receive a field-applied jacket, install fitted PVC cover over elbows, tees, strainers, valves, flanges, and unions. Terminate ends with PVC end caps. Tape PVC covers to adjoining insulation facing using PVC tape.
  9. Stencil or label the outside insulation jacket of each union with the word "union." Match size and color of pipe labels.
- C. Insulate instrument connections for thermometers, pressure gages, pressure temperature taps, test connections, flow meters, sensors, switches, and transmitters on insulated pipes. Shape insulation at these connections by tapering it to and around the connection with insulating cement and finish with finishing cement, mastic, and flashing sealant.
- D. Install removable insulation covers at locations indicated. Installation shall conform to the following:
1. Make removable flange and union insulation from sectional pipe insulation of same thickness as that on adjoining pipe. Install same insulation jacket as adjoining pipe insulation.
  2. When flange and union covers are made from sectional pipe insulation, extend insulation from flanges or union long at least two times the insulation thickness over adjacent pipe insulation on each side of flange or union. Secure flange cover in place with stainless-steel or aluminum bands. Select band material compatible with insulation and jacket.
  3. Construct removable valve insulation covers in same manner as for flanges, except divide the two-part section on the vertical center line of valve body.
  4. When covers are made from block insulation, make two halves, each consisting of mitered blocks wired to stainless-steel fabric. Secure this wire frame, with its attached insulation, to flanges with tie wire. Extend insulation at least 2 inches over adjacent pipe insulation on each side of valve. Fill space between flange or union cover and pipe insulation with insulating cement. Finish cover assembly with insulating cement applied in two coats. After first coat is dry, apply and trowel second coat to a smooth finish.
  5. Unless a PVC jacket is indicated in field-applied jacket schedules, finish exposed surfaces with a metal jacket.

### 3.06 INSTALLATION OF CELLULAR-GLASS INSULATION

- A. Insulation Installation on Straight Pipes and Tubes:
1. Secure each layer of insulation to pipe with wire or bands and tighten bands without deforming insulation materials.
  2. Where vapor barriers are indicated, seal longitudinal seams, end joints, and protrusions with vapor-barrier mastic and joint sealant.

3. For insulation with factory-applied jackets on above-ambient services, secure laps with outward-clinched staples at 6 inches o.c.
4. For insulation with factory-applied jackets on below-ambient services, do not staple longitudinal tabs. Instead, secure tabs with additional adhesive as recommended by insulation material manufacturer and seal with vapor-barrier mastic and flashing sealant.

B. Insulation Installation on Pipe Flanges:

1. Install preformed pipe insulation to outer diameter of pipe flange.
2. Make width of insulation section same as overall width of flange and bolts, plus twice the thickness of pipe insulation.
3. Fill voids between inner circumference of flange insulation and outer circumference of adjacent straight pipe segments with cut sections of cellular-glass block insulation of same thickness as pipe insulation.
4. Install jacket material with manufacturer's recommended adhesive, overlap seams at least 1 inch, and seal joints with flashing sealant.

C. Insulation Installation on Pipe Fittings and Elbows:

1. Install preformed sections of same material as straight segments of pipe insulation when available. Secure according to manufacturer's written instructions.
2. When preformed sections of insulation are not available, install mitered sections of cellular-glass insulation. Secure insulation materials with wire or bands.

D. Insulation Installation on Valves and Pipe Specialties:

1. Install preformed sections of cellular-glass insulation to valve body.
2. Arrange insulation to permit access to packing and to allow valve operation without disturbing insulation.
3. Install insulation to flanges as specified for flange insulation application.

### 3.07 INSTALLATION OF MINERAL-FIBER INSULATION

A. Insulation Installation on Straight Pipes and Tubes:

1. Secure each layer of preformed pipe insulation to pipe with wire or bands and tighten bands without deforming insulation materials.
2. Where vapor barriers are indicated, seal longitudinal seams, end joints, and protrusions with vapor-barrier mastic and joint sealant.
3. For insulation with factory-applied jackets on above-ambient surfaces, secure laps with outward-clinched staples at 6 inches o.c.
4. For insulation with factory-applied jackets on below-ambient surfaces, do not staple longitudinal tabs. Instead, secure tabs with additional adhesive as recommended by insulation material manufacturer and seal with vapor-barrier mastic and flashing sealant.

B. Insulation Installation on Pipe Flanges:

1. Install preformed pipe insulation to outer diameter of pipe flange.
2. Make width of insulation section same as overall width of flange and bolts, plus twice the thickness of pipe insulation.

3. Fill voids between inner circumference of flange insulation and outer circumference of adjacent straight pipe segments with mineral-fiber blanket insulation.
4. Install jacket material with manufacturer's recommended adhesive, overlap seams at least 1 inch, and seal joints with flashing sealant.

C. Insulation Installation on Pipe Fittings and Elbows:

1. Install preformed sections of same material as straight segments of pipe insulation when available.
2. When preformed insulation elbows and fittings are not available, install mitered sections of pipe insulation, to a thickness equal to adjoining pipe insulation. Secure insulation materials with wire or bands.

D. Insulation Installation on Valves and Pipe Specialties:

1. Install preformed sections of same material as straight segments of pipe insulation when available.
2. When preformed sections are not available, install mitered sections of pipe insulation to valve body.
3. Arrange insulation to permit access to packing and to allow valve operation without disturbing insulation.
4. Install insulation to flanges as specified for flange insulation application.

### 3.08 FIELD-APPLIED JACKET INSTALLATION

A. Where glass-cloth jackets are indicated, install directly over bare insulation or insulation with factory-applied jackets.

1. Draw jacket smooth and tight to surface with 2-inch overlap at seams and joints.
2. Embed glass cloth between two 0.062-inch- thick coats of lagging adhesive.
3. Completely encapsulate insulation with coating, leaving no exposed insulation.

B. Where PVC jackets are indicated, install with 1-inch overlap at longitudinal seams and end joints; for horizontal applications. Seal with manufacturer's recommended adhesive.

1. Apply two continuous beads of adhesive to seams and joints, one bead under lap and the finish bead along seam and joint edge.

C. Where metal jackets are indicated, install with 2-inch overlap at longitudinal seams and end joints. Overlap longitudinal seams arranged to shed water. Seal end joints with weatherproof sealant recommended by insulation manufacturer. Secure jacket with stainless-steel bands 12 inches o.c. and at end joints.

### 3.09 FINISHES

A. Pipe Insulation with ASJ, Glass-Cloth, or Other Paintable Jacket Material: Paint jacket with paint system identified below and as specified in Section 099113 "Exterior Painting" and Section 099123 "Interior Painting."

1. Flat Acrylic Finish: Two finish coats over a primer that is compatible with jacket material and finish coat paint. Add fungicidal agent to render fabric mildew proof.
  - a. Finish Coat Material: Interior, flat, latex-emulsion size.
- B. Color: Final color as selected by Architect. Vary first and second coats to allow visual inspection of the completed Work.
- C. Do not field paint aluminum or stainless-steel jackets.

### 3.10 FIELD QUALITY CONTROL

- A. Tests and Inspections:
  1. Inspect pipe, fittings, strainers, and valves, randomly selected by Architect, by removing field-applied jacket and insulation in layers in reverse order of their installation. Extent of inspection shall be limited to three locations of straight pipe, three locations of threaded fittings, three locations of welded fittings, two locations of threaded strainers, two locations of welded strainers, three locations of threaded valves, and three locations of flanged valves for each pipe service defined in the "Piping Insulation Schedule, General" Article.
- B. All insulation applications will be considered defective Work if sample inspection reveals noncompliance with requirements.

### 3.11 PIPING INSULATION SCHEDULE, GENERAL

- A. Acceptable preformed pipe and tubular insulation materials and thicknesses are identified for each piping system and pipe size range. If more than one material is listed for a piping system, selection from materials listed is Contractor's option.
- B. Items Not Insulated: Unless otherwise indicated, do not install insulation on the following:
  1. Drainage piping located in crawl spaces.
  2. Underground piping.
  3. Chrome-plated pipes and fittings unless there is a potential for personnel injury.

### 3.12 PIPING INSULATION SCHEDULE

- A. Indoor Heating-Hot-Water Supply and Return:
  1. NPS 1-1/4 and Smaller: Insulation shall be one of the following:
    - a. Mineral-Fiber, Preformed Pipe, Type I: 1-1/2 inches thick.
  2. NPS 1-1/2 and Larger: Insulation shall be one of the following:
    - a. Mineral-Fiber, Preformed Pipe, Type I or Pipe and Tank Insulation: 2 inches thick.

B. Outdoor Heating-Hot-Water Supply and Return:

- a. Cellular Glass: 2 inches thick.

3.13 INDOOR, FIELD-APPLIED JACKET SCHEDULE

- A. Install jacket over insulation material. For insulation with factory-applied jacket, install the field-applied jacket over the factory-applied jacket.
- B. If more than one material is listed, selection from materials listed is Contractor's option.
- C. Piping, Exposed:
  1. PVC: 20 mils thick.

3.14 OUTDOOR, FIELD-APPLIED JACKET SCHEDULE

- A. Install jacket over insulation material. For insulation with factory-applied jacket, install the field-applied jacket over the factory-applied jacket.
- B. If more than one material is listed, selection from materials listed is Contractor's option.
- C. Piping, Exposed:
  1. Aluminum, Embossed : 0.016 inch thick.

END OF SECTION

## SECTION 232113.13 - UNDERGROUND DIRECT BURIED HYDRONIC PIPING

### PART 1 - GENERAL

#### 1.1 SUMMARY:

- A. This specification shall apply to all underground piping.
- B. All underground 180°F hot water lines shall be designed per ANSI B31.1 for and shall be a factory preinsulated pipe system. Installation of the piping system shall be in accordance with the manufacturer's instructions. Factory trained field technical assistance shall be provided for critical periods of installation, field joint instruction and testing.
- C. The manufacturer shall design system for 180°F hot water and shall provide and design a complete and operable system including piping expansion joints, anchors, guides, supports and all necessary appurtenances.
- D. The following manufacturers can provide material as long as they meet this specification: PERMA-PIPE, Rovanco or Thermacor, or prior approved equal.

#### 1.2 SUBMITTALS:

- A. The manufacturer shall submit the following information prior to release for production;
  - 1. Complete pipe system layout drawings including sizes and locations of all expansion loops, guides, supports and anchors.
  - 2. Complete details of all components being used.
  - 3. Certificate of factory field service personnel performing site field service.
  - 4. Insulation bonding procedures used in project.

#### 1.3 QUALITY ASSURANCE:

- A. The piping system manufacturer shall provide a factory trained technical support person on site during the installation of the piping system, field joint assembly instruction (all joints must remain exposed by the Contractor for inspection by the factory-trained field service inspector), shrink sleeve installation and final system testing. The support person cannot be the contractor trained on the installation. Only factory trained and certified support personnel shall provide written reports signed by the contractor that the installation was in accordance with the manufacturer's installation instructions.

### PART 2 - PRODUCT

#### 2.1 SERVICE PIPE:

- A. The service pipe shall be standard weight ASTM A53 Gr. B ERW carbon steel. All joints



shall be butt-welded for 2 1/2" and larger, and socket or butt-welded for 2" and smaller. Where possible, straight sections shall be supplied in 40-foot random lengths with piping exposed at each end for field joint fabrication.

2.2 INSULATION:

- A. The service pipe insulation shall be polyurethane foam with 2 lb/ft<sup>3</sup> minimum density, 90% minimum closed cell content, minimum compressive strength of 40 psig and initial thermal conductivity of 0.16 Btu-in/hr/ft<sup>2</sup>/°F. The insulation shall completely fill the annular space between the service pipe and jacket and shall be bonded to both. Systems using open cell insulation or a non-bonded design shall not be allowed.
- B. The insulation shall be provided to the minimum thickness specified below:

Pipe Size (in.)	Minimum Insulation Thickness (in.)	
	1 to 8	1
10 to 18	1.5	

2.3 INSULATION JACKET:

- A. The outer protective insulation jacket shall be seamless high-density polyethylene (HDPE) in accordance with ASTM D3350, minimum cell classification PE345444C. PVC or tape materials are not allowed. The minimum thickness of the HDPE jacket shall be as follows:

Jacket OD (in.)	Minimum Jacket Thickness (in.)
OD ≤ 12	0.125
OD > 12	0.150

Piping that is exposed to the weather shall also have a stainless steel jacket.

2.4 FITTINGS:

- A. All elbows shall be factory preinsulated and molded outer jacket, tees shall be preinsulated, with extrusion welded jacket, anchors shall be factory preinsulated and sealed to prevent moisture no metal shall be exposed to concrete or earth. No shrink wrap or tape shall be allowed on fittings.

2.5 UNDERGROUND WARNING TAPE

- A. Minimum 3 inch wide polyethylene detectable type marking tape. The tape shall be resistant to alkalis, acids and other destructive agents found in soil and impregnated with metal so that it can be readily recognized after burial by standard locating equipment.
  1. Lamination bond of one (1) layer of Minimum 0.35 mils thick aluminum foil between two (2) layers of minimum 4.3 mils thick inert plastic film.
  2. Minimum tensile strength: 63 LBS per 3 IN width.

3. Minimum elongation: 500 percent.
4. Provide continuous yellow with black letter printed message repeated every 16 to 36 inches warning of pipe buried below (e.g.: "CAUTION HOT WATER LINE BURIED BELOW"). Tape shall be manufactured by Reef Industries "Terra Tape" or approved equal.

### PART 3 - EXECUTION

#### 3.1 FIELD JOINTS:

- A. Contractor shall paint all exposed pipe prior to foaming joint area, Insulation shall then be poured in place into the field joint area and visually inspected to insure no voids. No joints shall be insulated unless visually inspected, No pouring of foam into sleeves will be allowed. All field-applied insulation shall be placed only in straight sections of pipe. The installer shall seal the field joint area with a heat shrinkable adhesive backed sleeve. Backfilling shall not begin until the heat shrink sleeve has cooled.
- B. All insulation and jacketing materials for the field joint shall be furnished by manufacturer. All field joint areas must be visually inspected after foaming of joints to insure the joint area is void free. No sleeves or shrink-wrap shall be applied without visual inspection.

#### 3.2 WARNING TAPE

- A. Buried Utility Warning and Identification Tape:
  1. Provide detectable aluminum foil plastic backed tape or detectable magnetic plastic tape manufactured specifically for warning and identification of buried piping.
  2. Tape shall be detectable by an electronic detection instrument.
  3. Provide tape in rolls, 6" minimum width, color, yellow, with warning and identification imprinted in big black letters continuously and repeatedly over entire tape length.
  4. Warning and identification shall read CAUTION BURIED HOT WATER DISTRIBUTION PIPING BELOW or similar wording.
  5. Use permanent code and letter coloring unaffected by moisture and other substances contained in trench backfill material.
  6. Tape shall be installed 1-foot above each pipe in trench

#### 3.3 BACKFILL

- A. A 4-inch layer of sand, stone dust or fine gravel shall be placed and tamped in the trench to provide uniform bedding for the pipe. The entire trench width shall be evenly backfilled with a similar material as the bedding in 6 inch compacted layers to a minimum height of 6 inches above the top of the insulated pipe. The remaining trench shall be evenly and continuously backfilled and compacted in uniform layers with suitable excavated soil.
- B. Pipe in trench shall be placed on sand bags for welding or bell holes at field joints, no wood shall hold pipe up in trench.

- C. Top of pipe jackets shall be 3'-0" below grade (minimum) across the site, unless special circumstances occur and the Engineer is informed for his review and approval for change.

END OF SECTION 232113.13